

Babies and Bayes Nets II: Observations, Interventions and Prior Knowledge

Tamar Kushnir
Alison Gopnik

Outline

- Part 1: Interventions vs Observations
 - Causal strength judgments
 - Causal structure learning
- Part 2: Intervention Source
 - Causal strength judgments
 - Causal structure learning
- Part 3: Prior Knowledge
 - Integrating prior knowledge
 - Overriding prior knowledge

Part 1: Interventions vs. Observations

- Do we distinguish between observations and interventions in making inferences about causal strength? (Waldmann & Hagmayer, in press; Sloman & Lagnado, 2005)

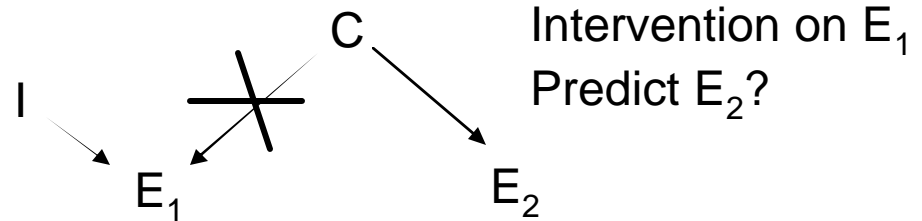
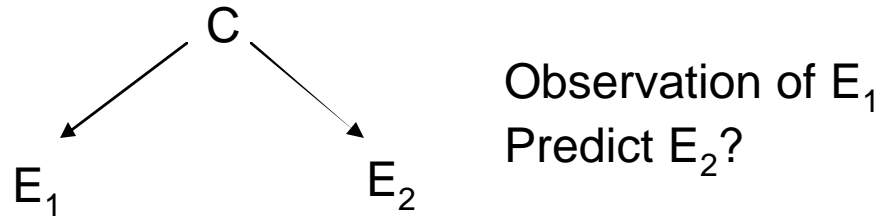
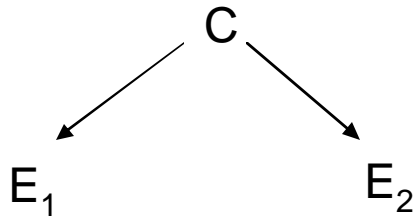

- Given structure
- Given observational data
- Adults make different inferences about hypothetical interventions than about hypothetical observations

Part 1: Interventions vs. Observations

- Do we distinguish between observations and interventions in causal structure learning?
- Stick ball machine: Gopnik et al 2004; Kushnir et al, 2003
 - No special instructions about interventions
 - Matched (between conditions) for pattern of movement.
 - Study 1 (Adults): No interventions
 - Study 2 (Children): No observations

Observations Only

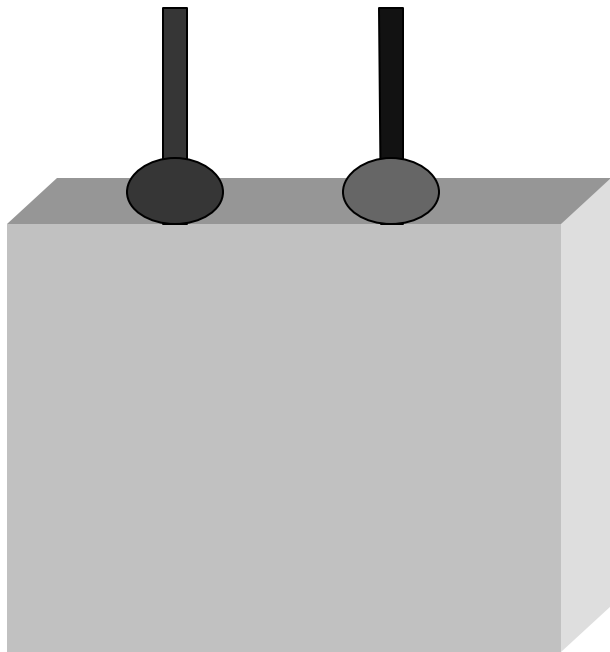

Observations & Interventions

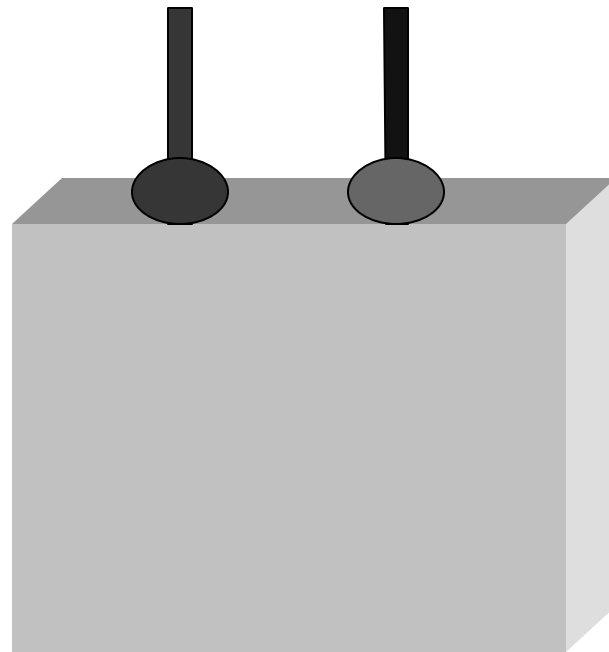

Observations Only

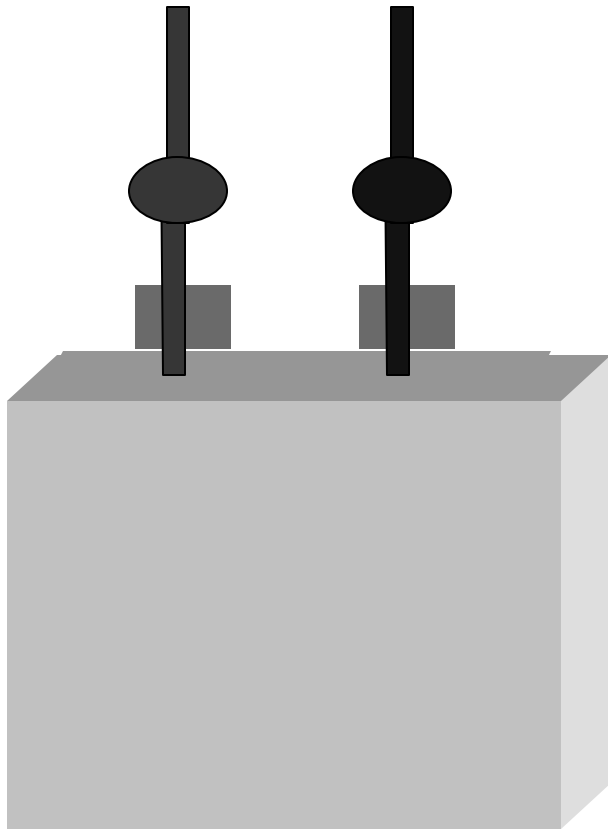

T. Kushnir, Few 2005

Observations & Interventions

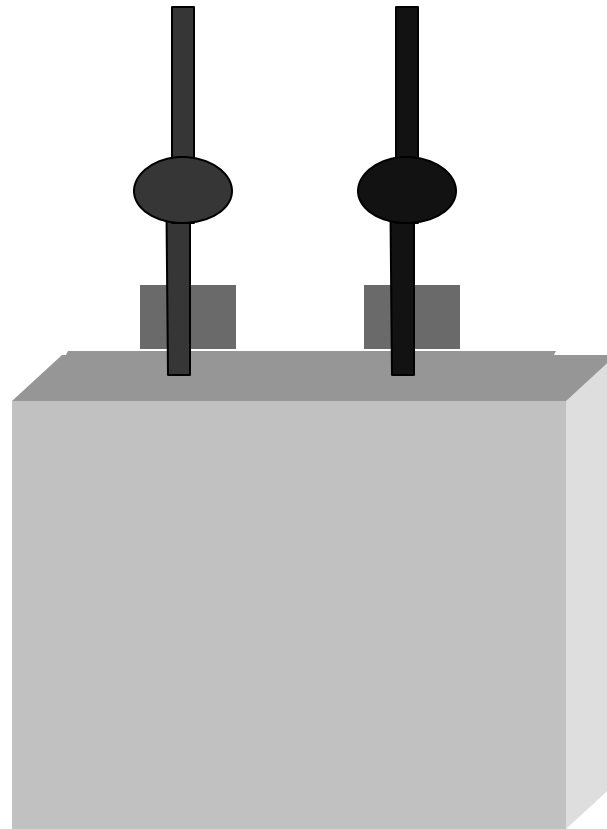

Kushnir et al, 2003

Observations Only

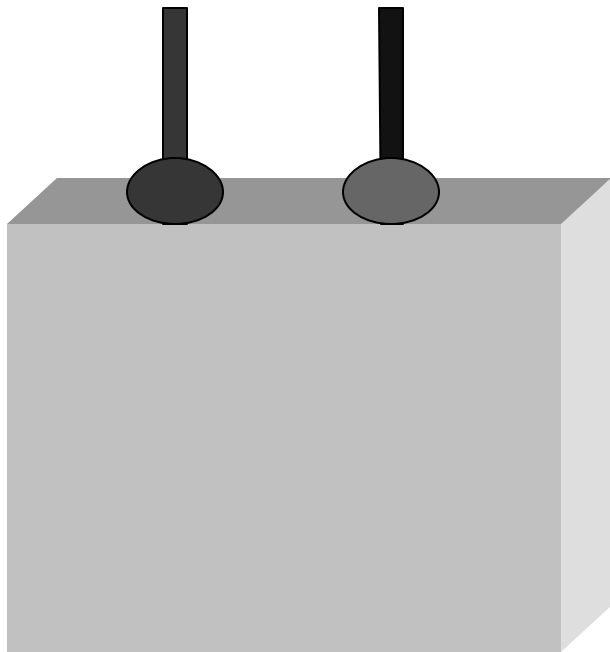

Observations & Interventions

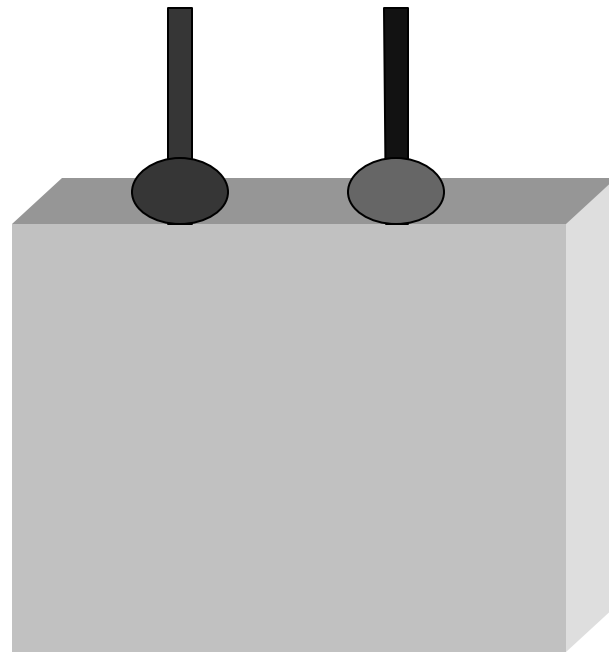

Observations Only

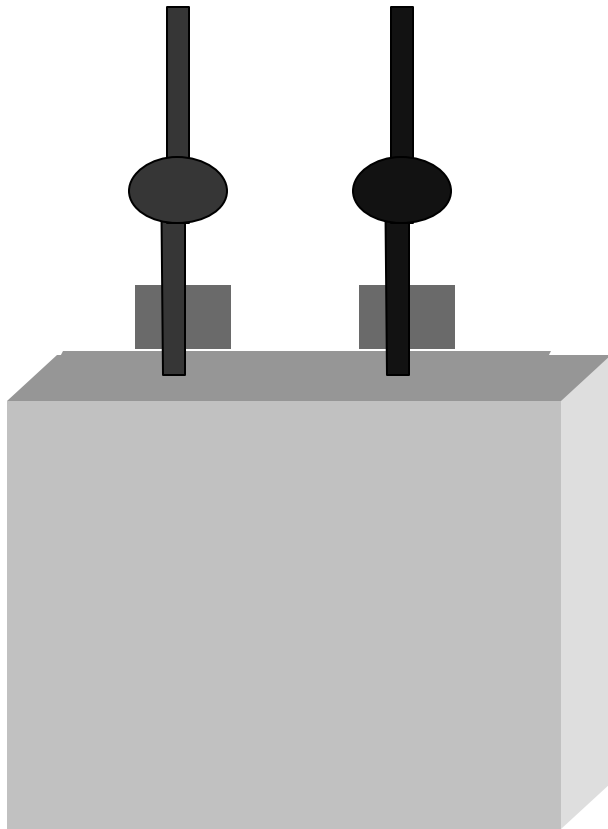

Observations & Interventions

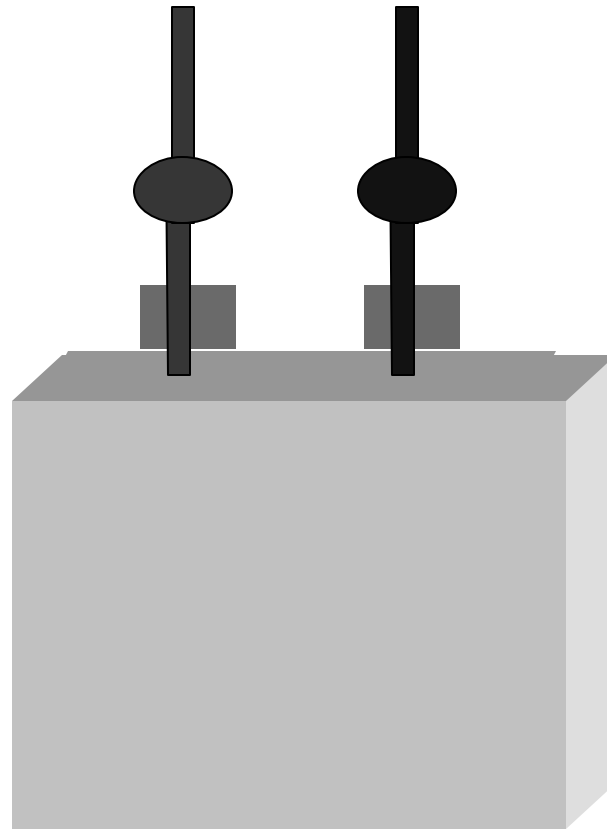

Observations Only

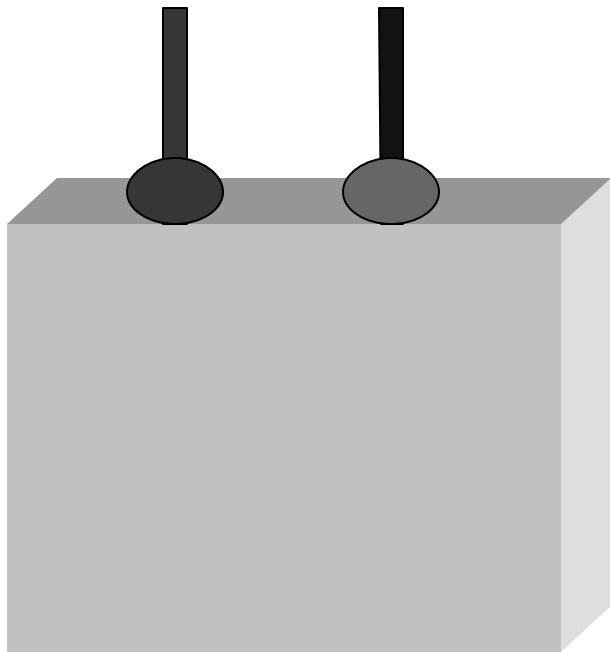

Observations & Interventions

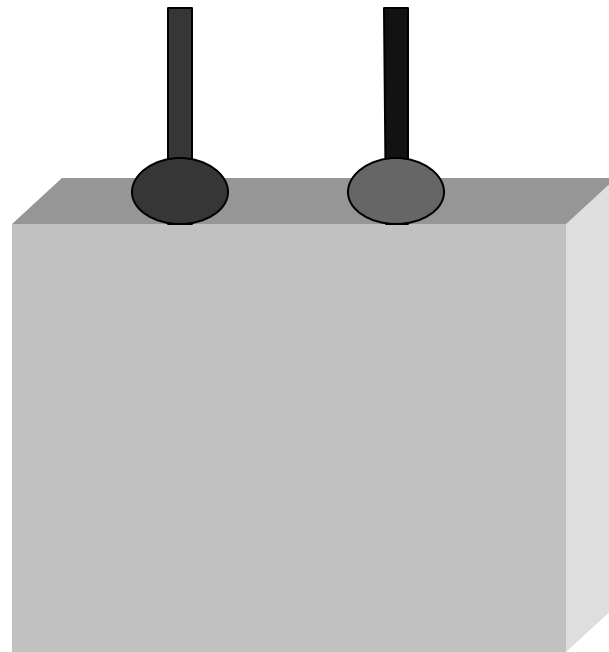

Observations Only

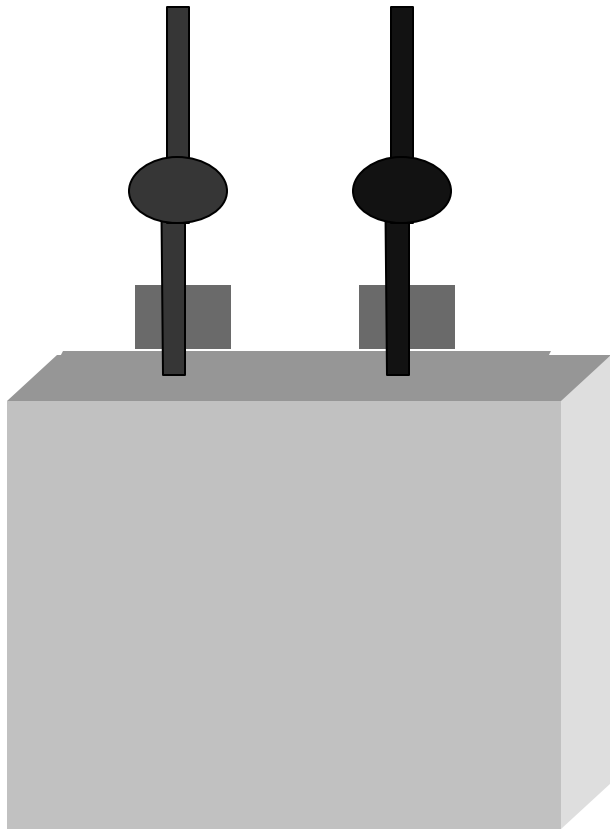

Observations & Interventions

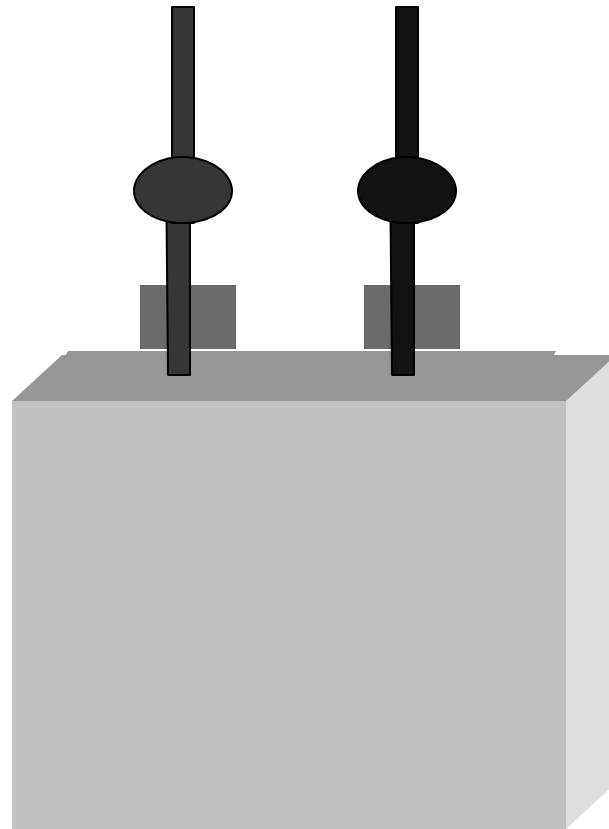

Observations Only

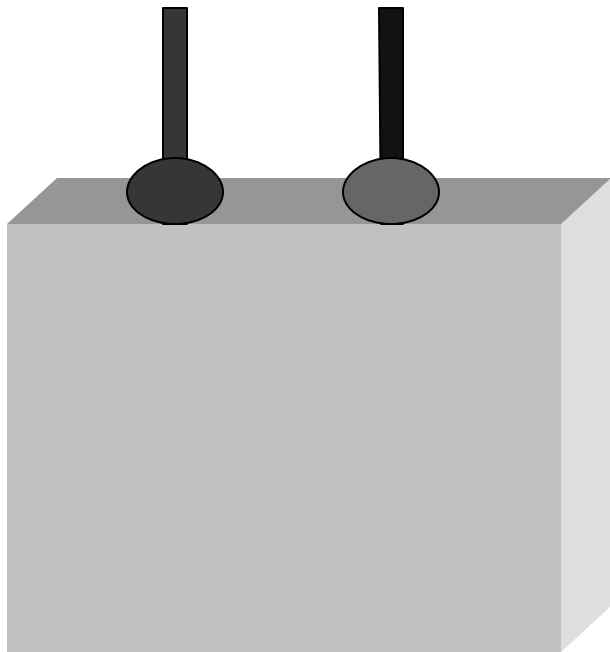

Observations & Interventions

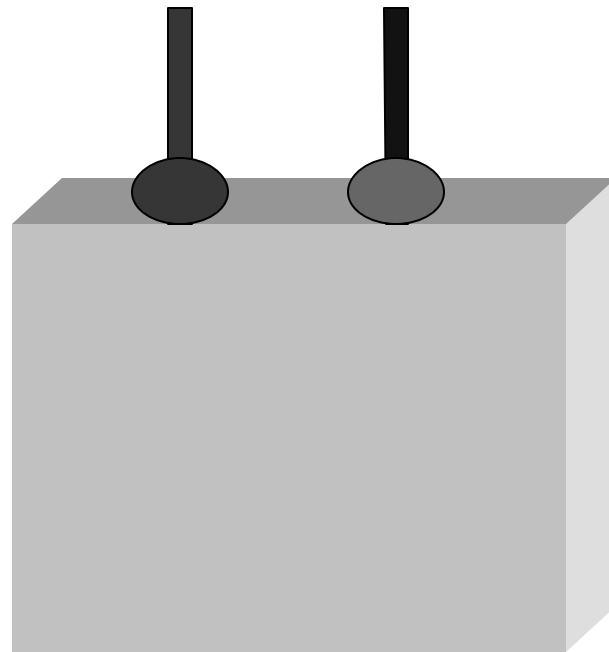

Observations Only

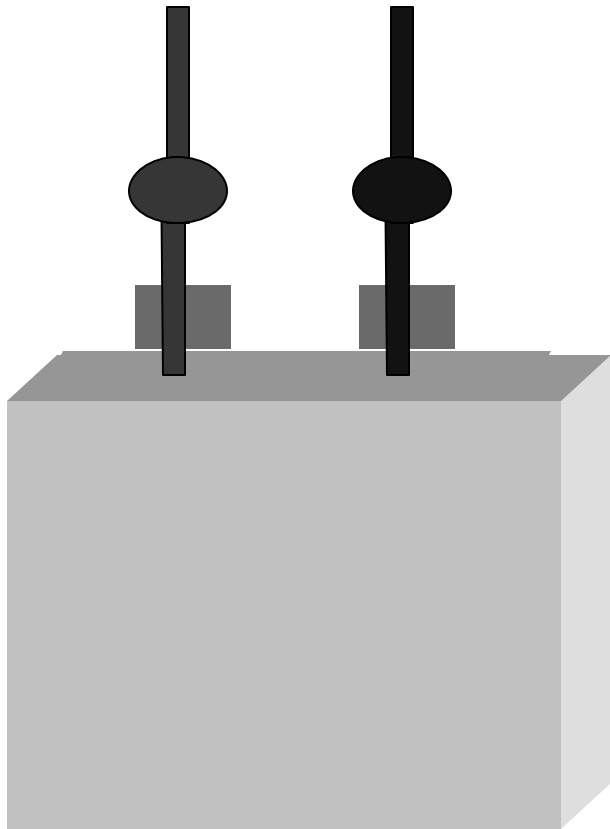

Observations & Interventions

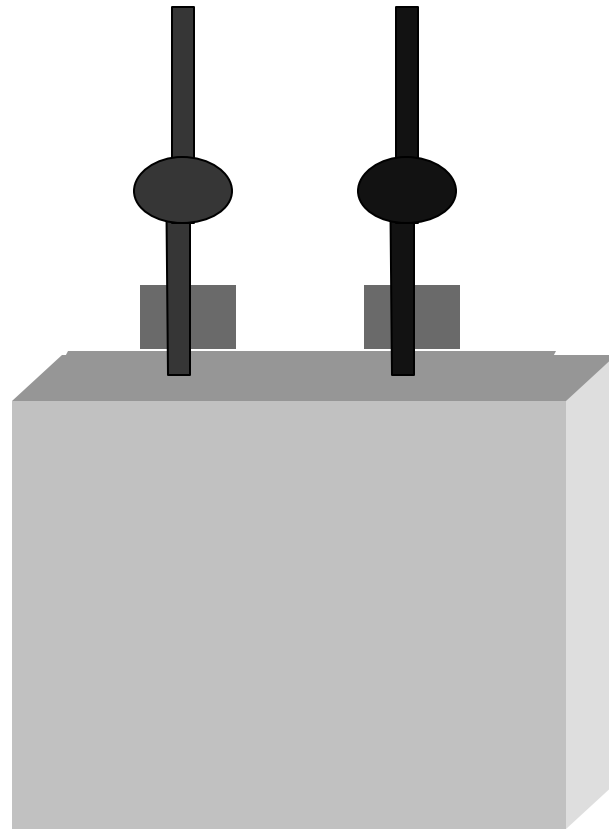

Observations Only

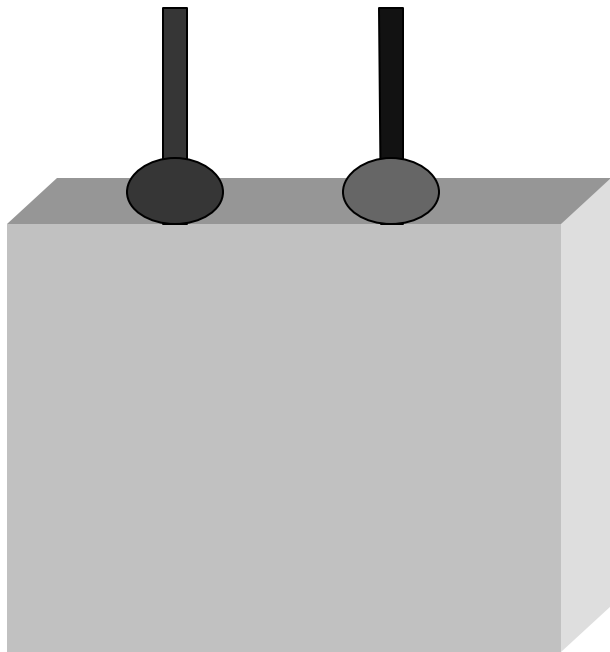

Observations & Interventions

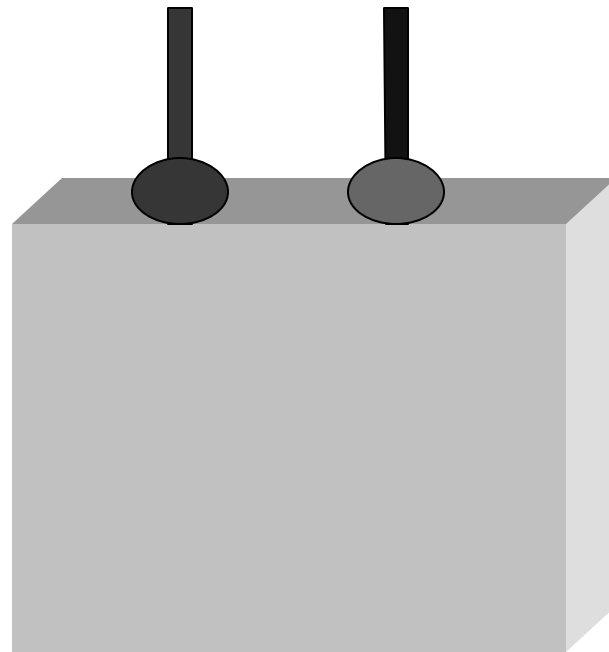

Observations Only

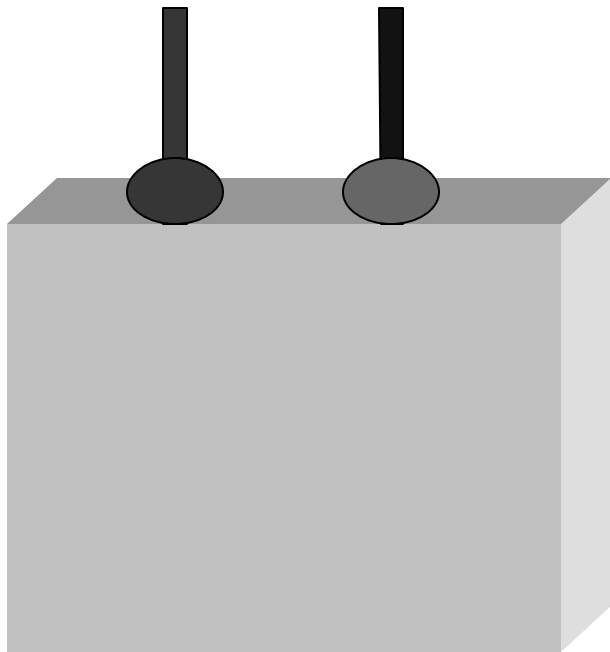

Observations & Interventions

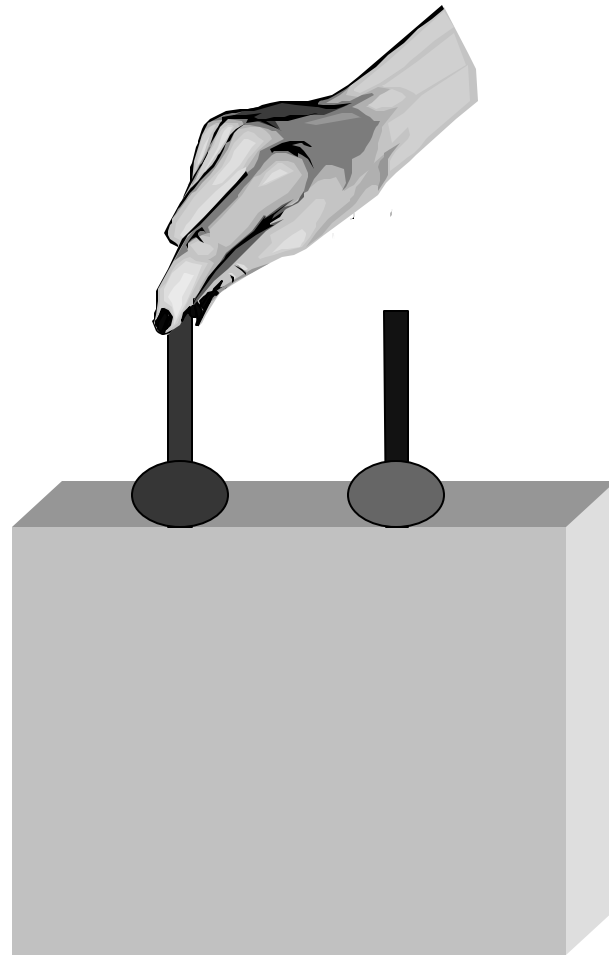

Observations Only

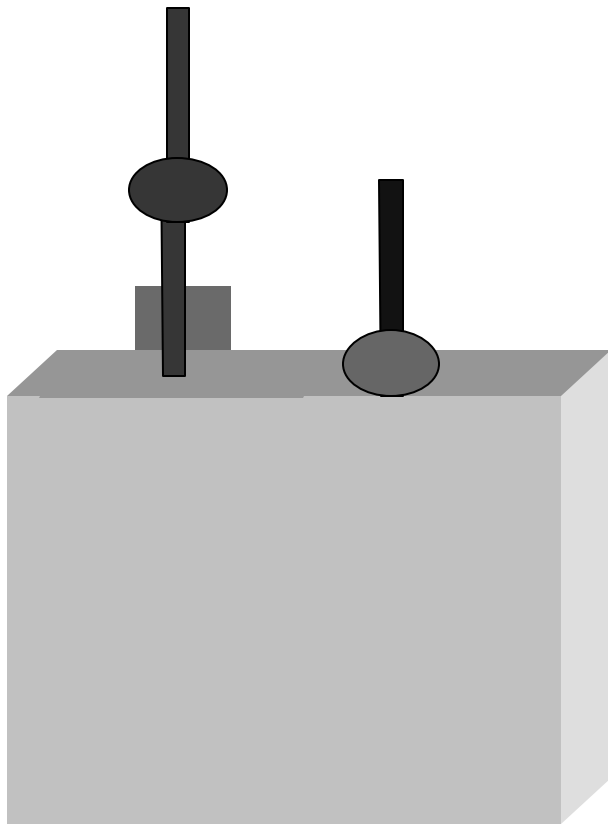

Observations & Interventions

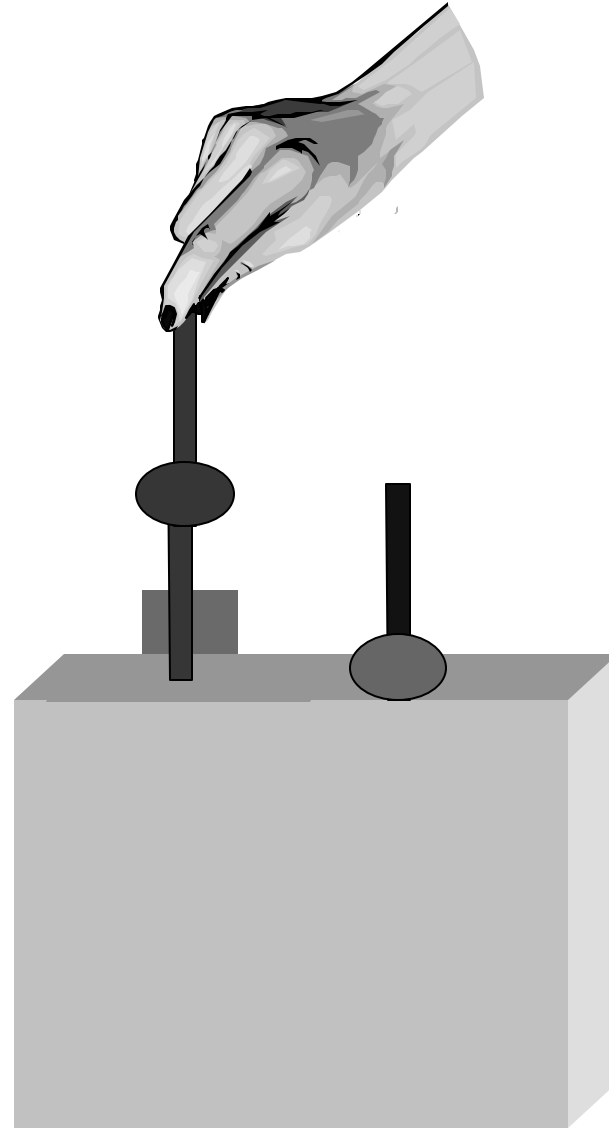

Observations Only

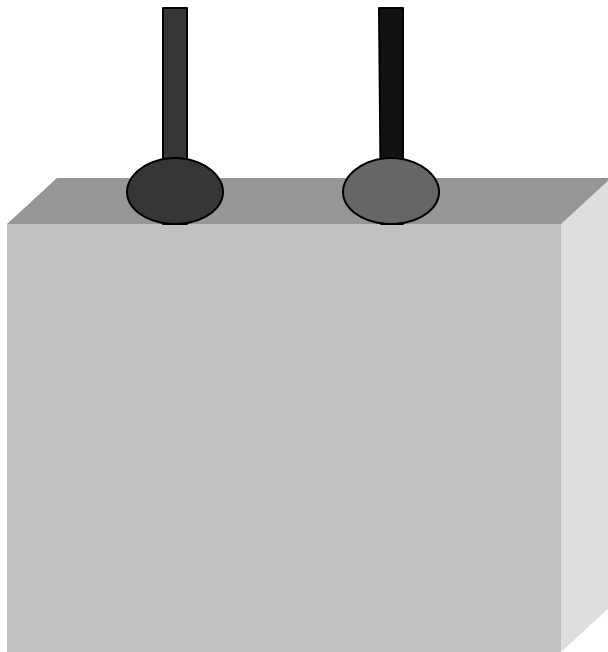

Observations & Interventions

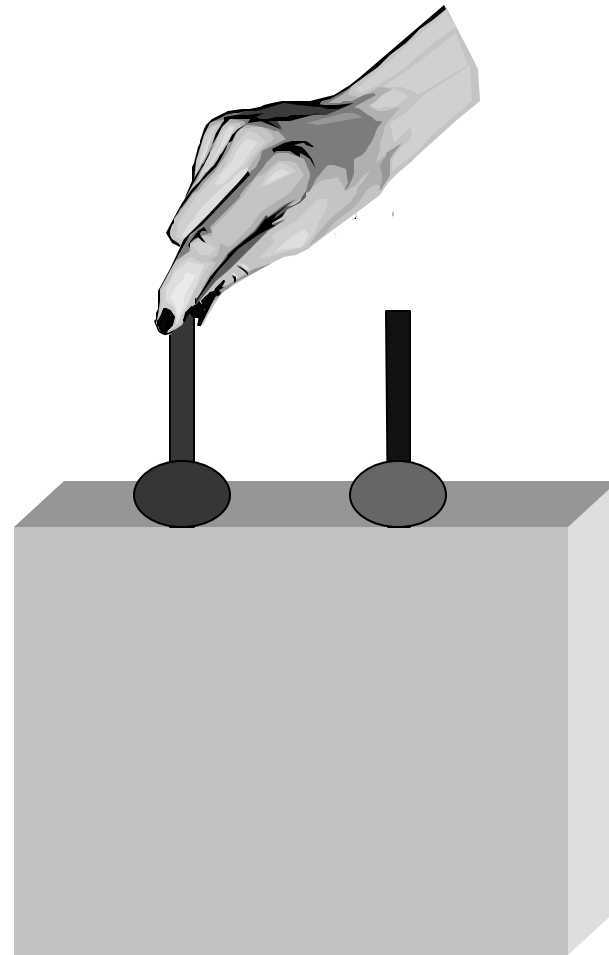

Observations Only

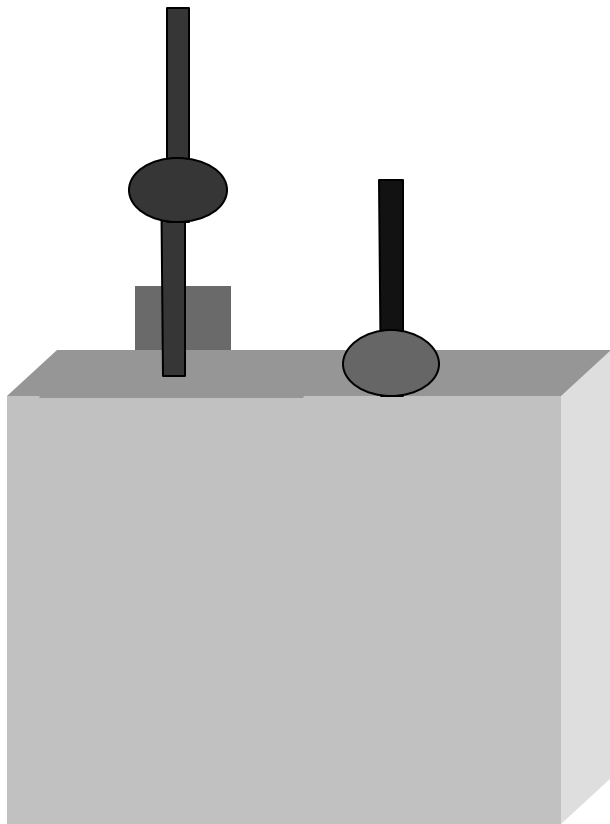

Observations & Interventions

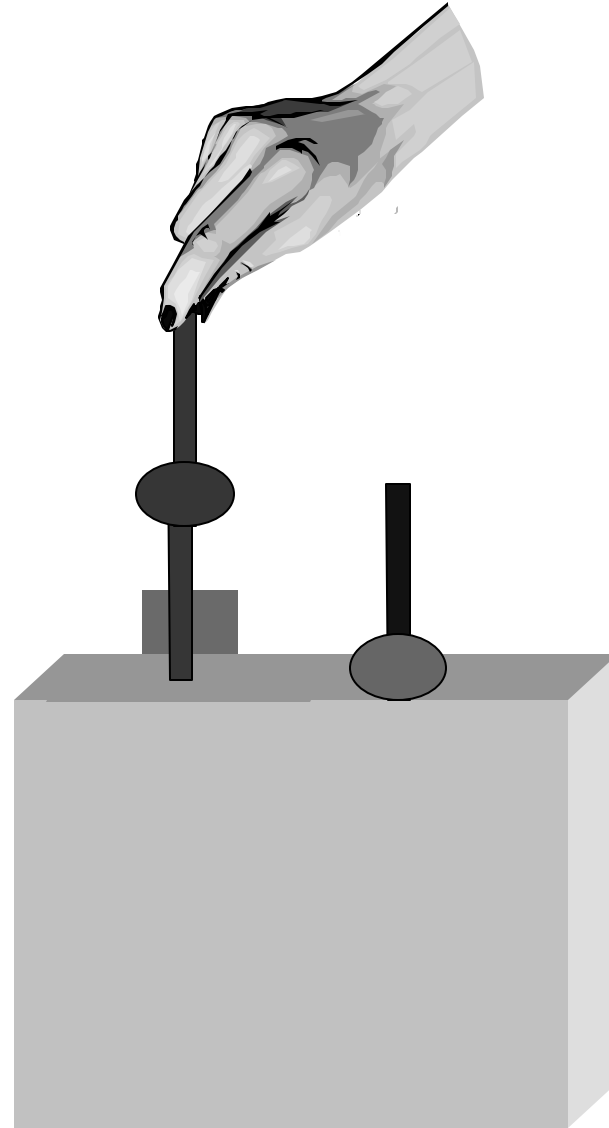

Observations Only

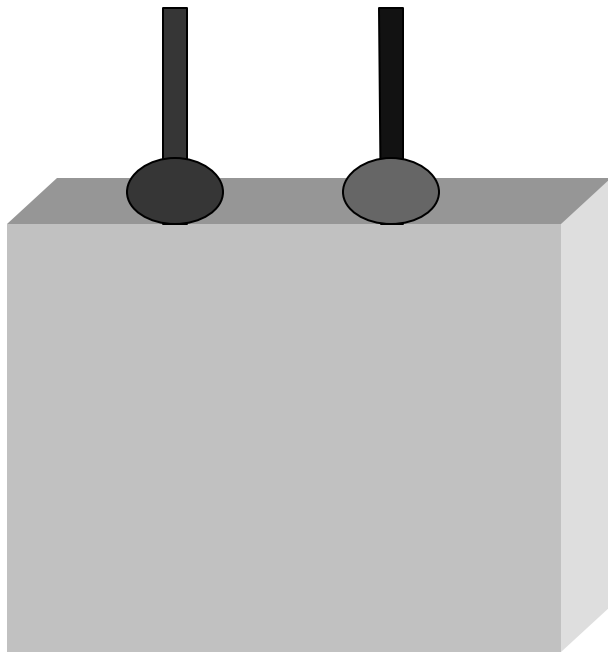

Observations & Interventions

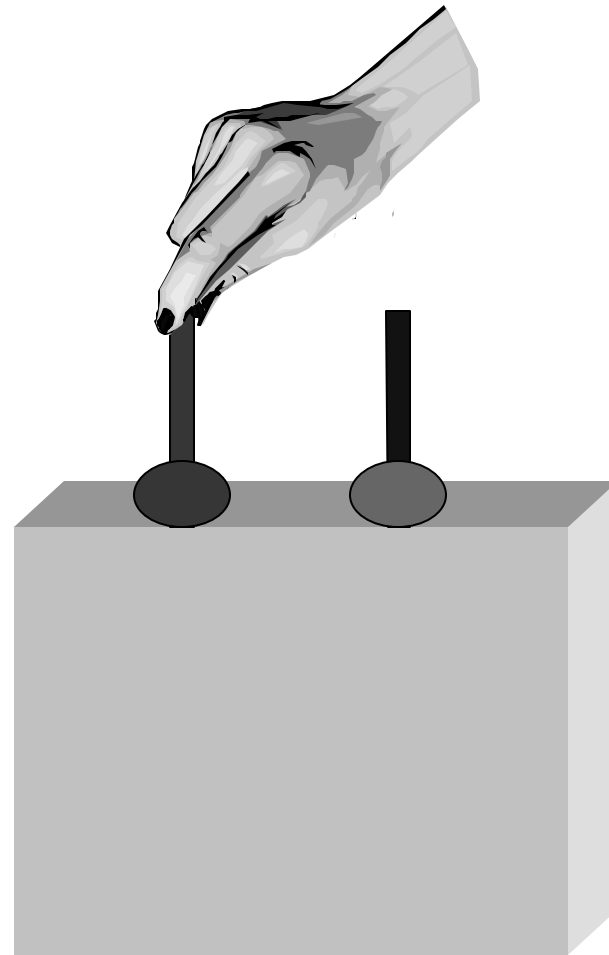

Observations Only

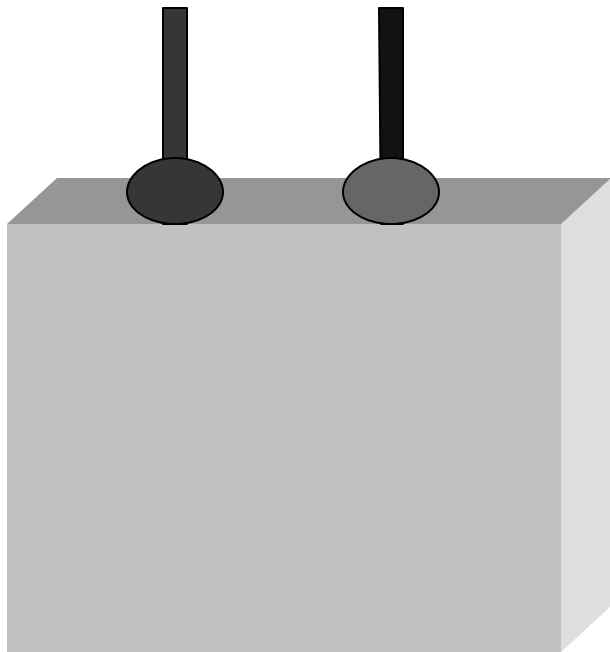

Observations & Interventions

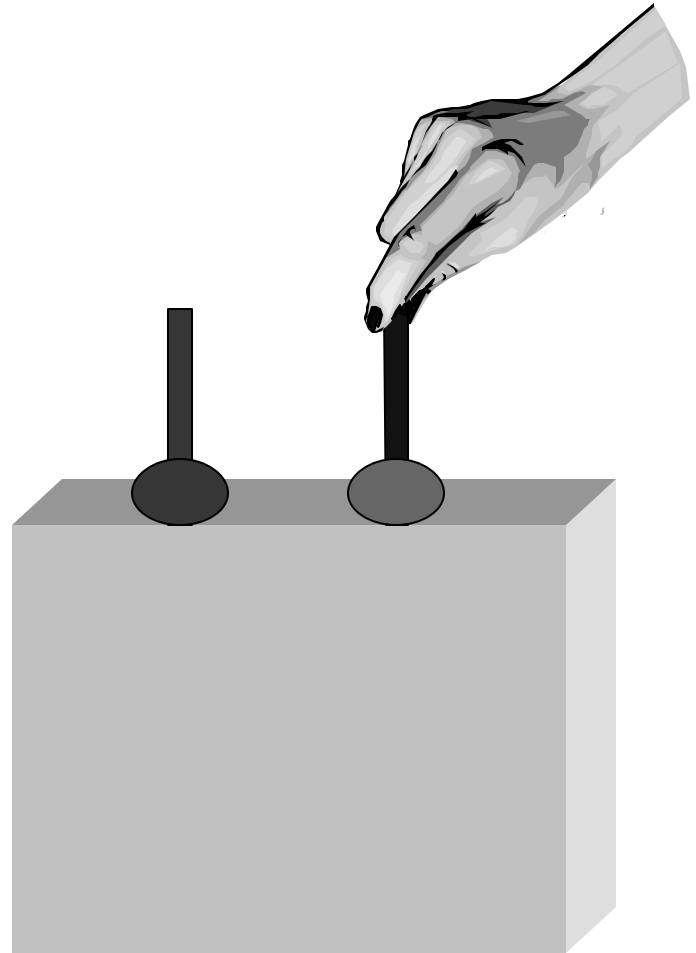

Observations Only

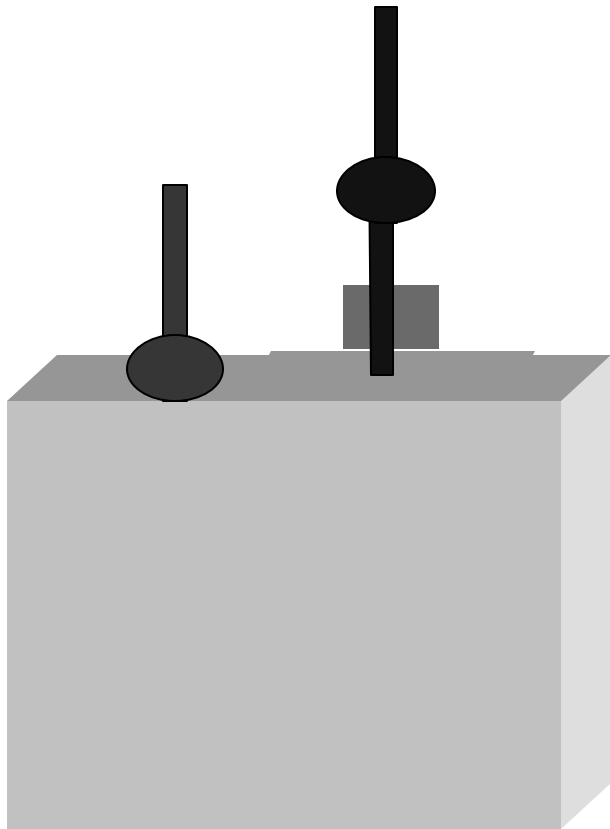

Observations & Interventions

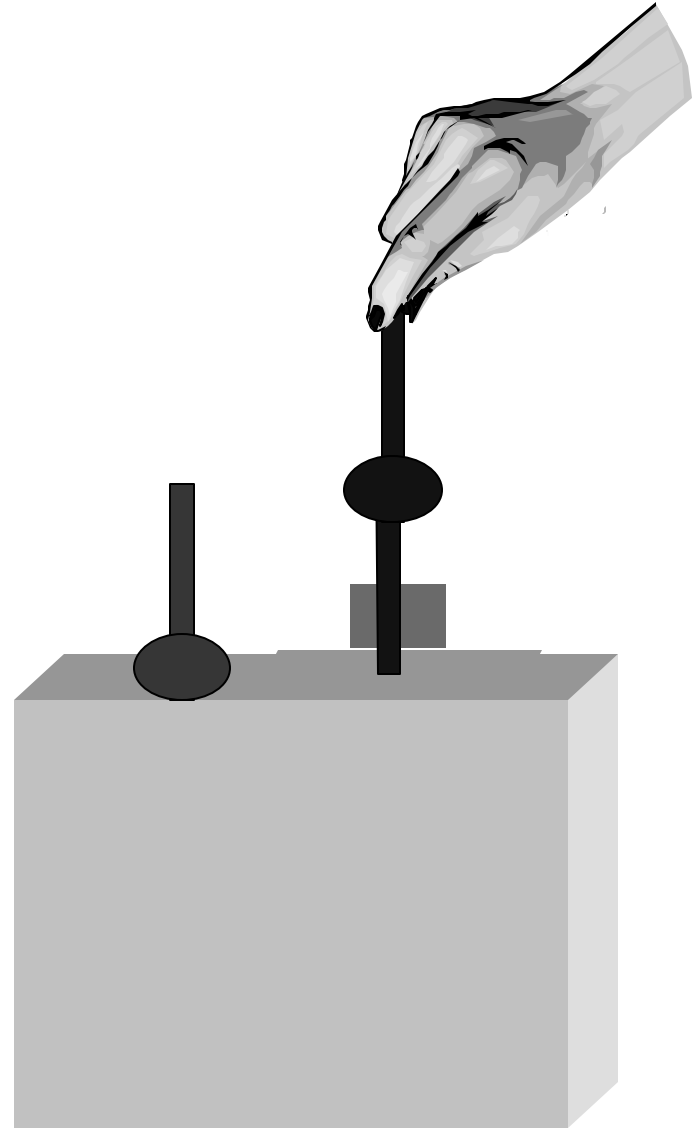

Observations Only

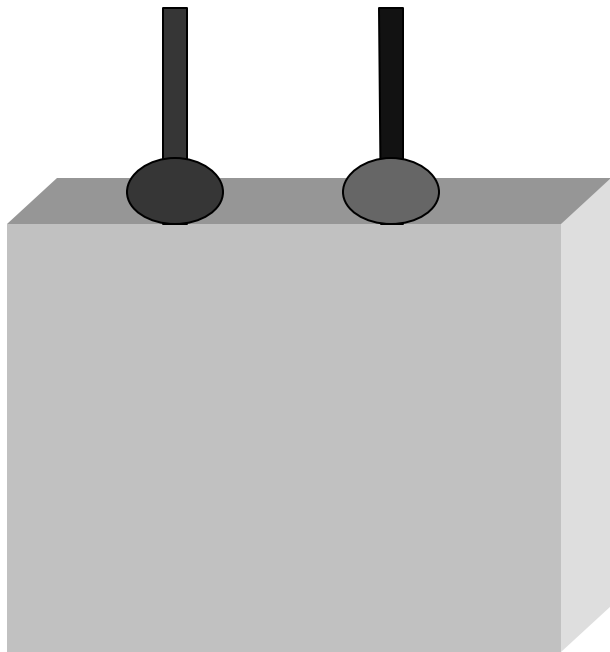

Observations & Interventions

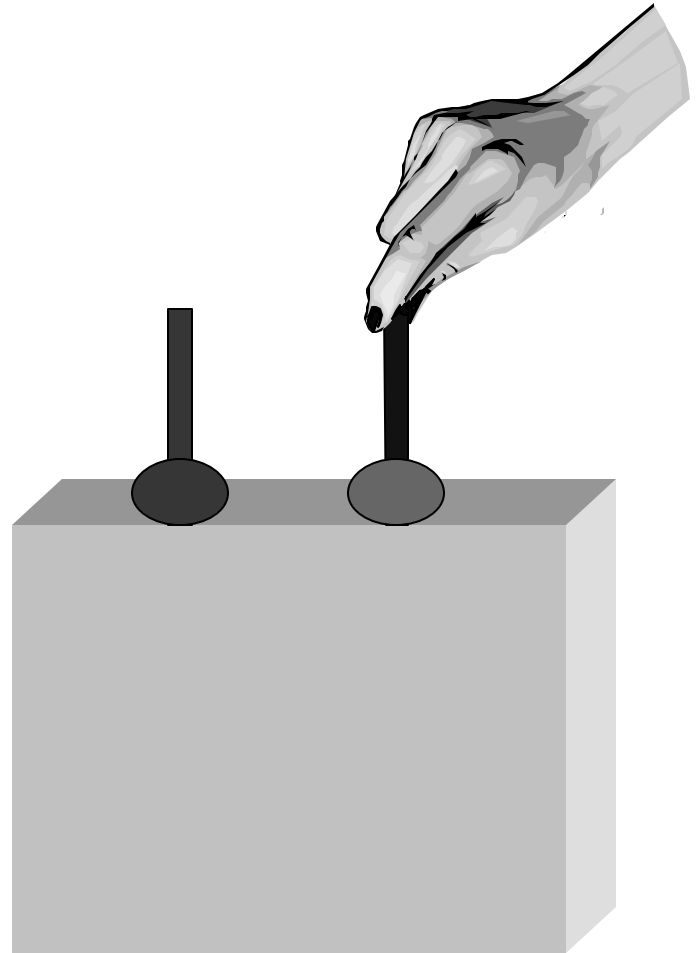

Observations Only

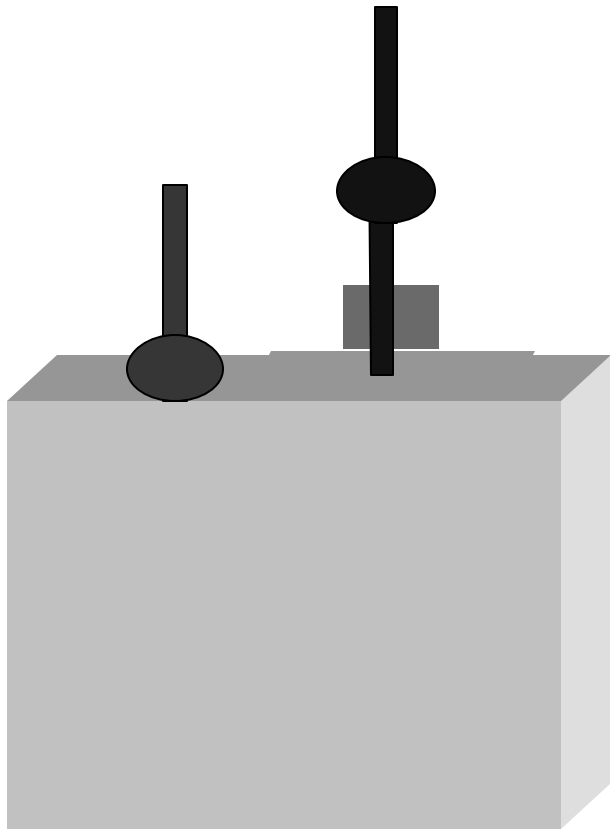

Observations & Interventions

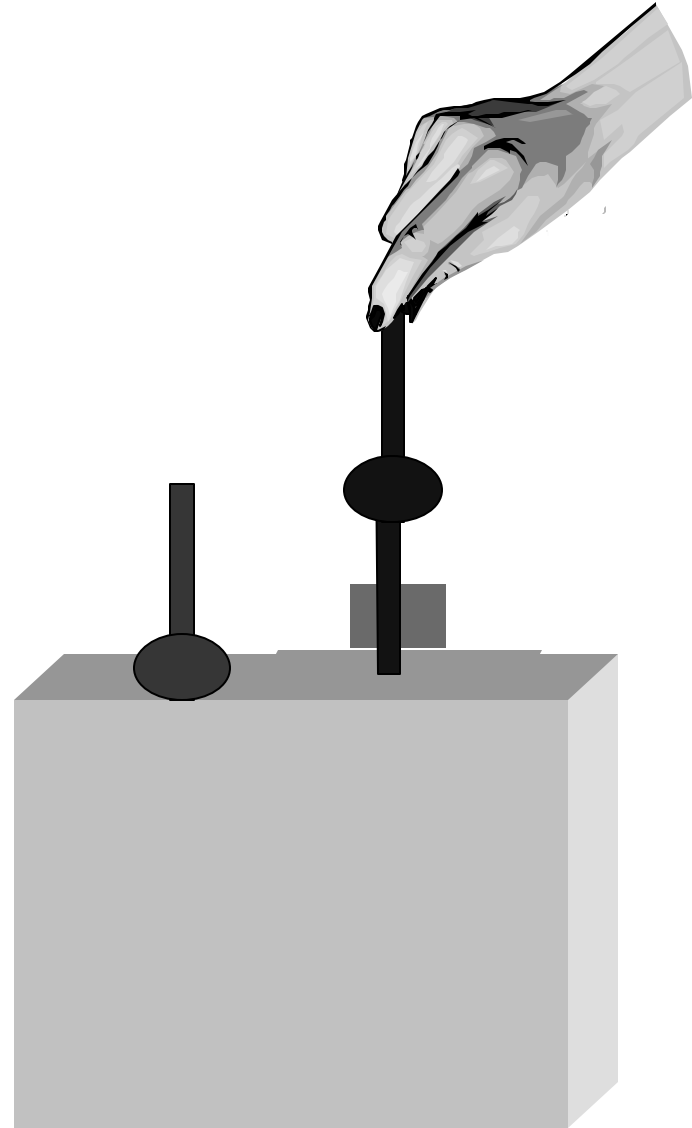

Observations Only

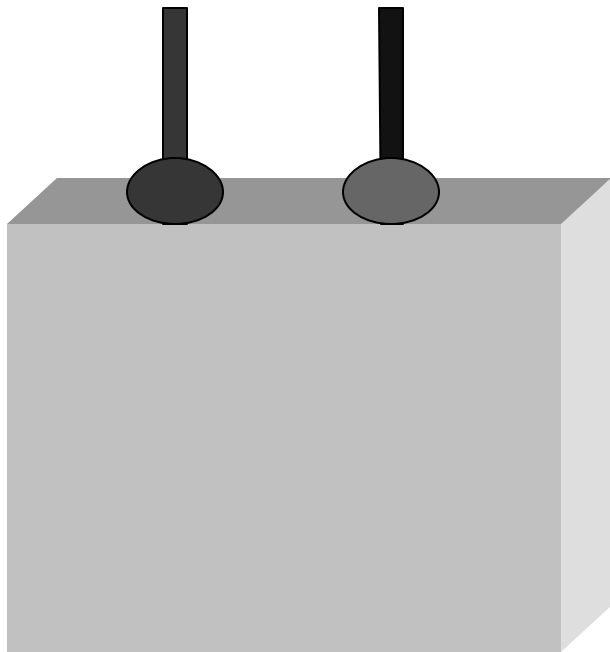

Observations & Interventions

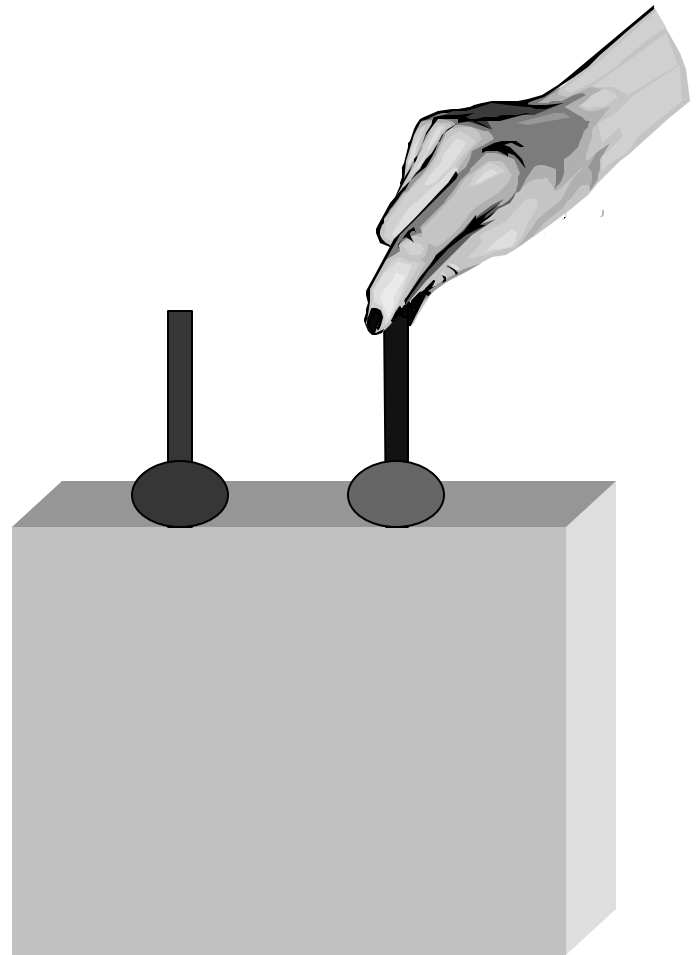

Observations Only

A & B – 4 times
A alone – 2 times
B alone – 2 times

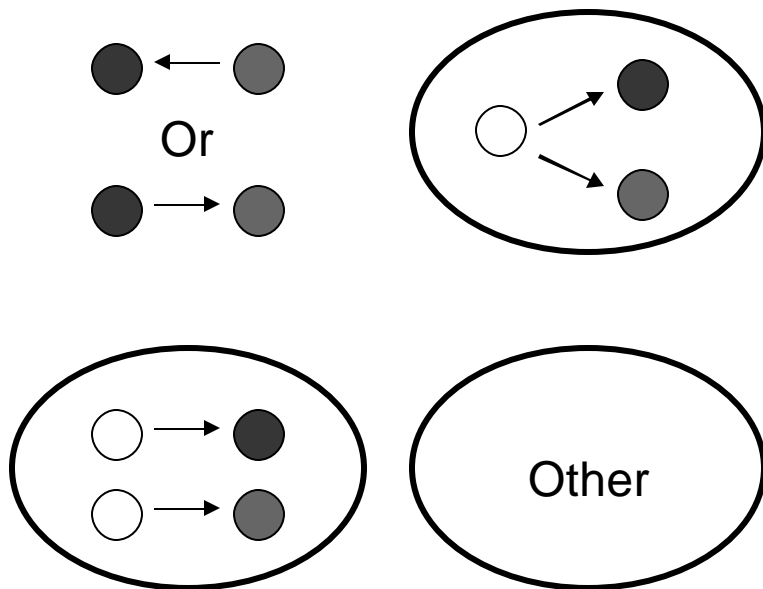

Observations & Interventions

A & B – 4 times
Intervene on A: A alone – 2 times
Intervene on B: B alone – 2 times

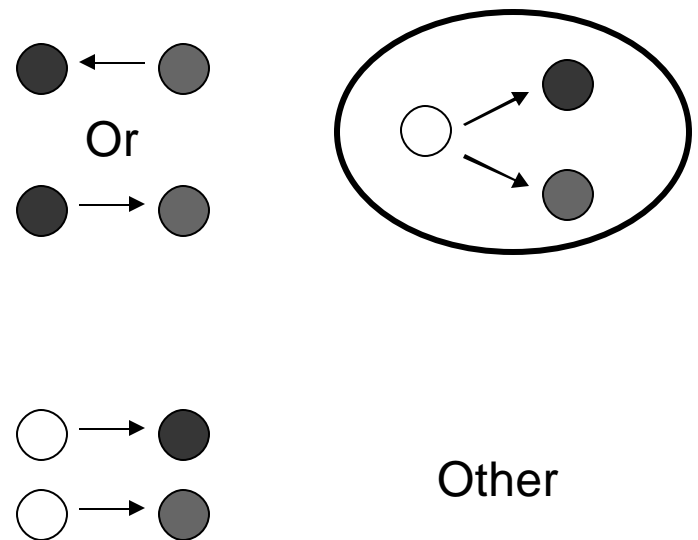

Interventions Only

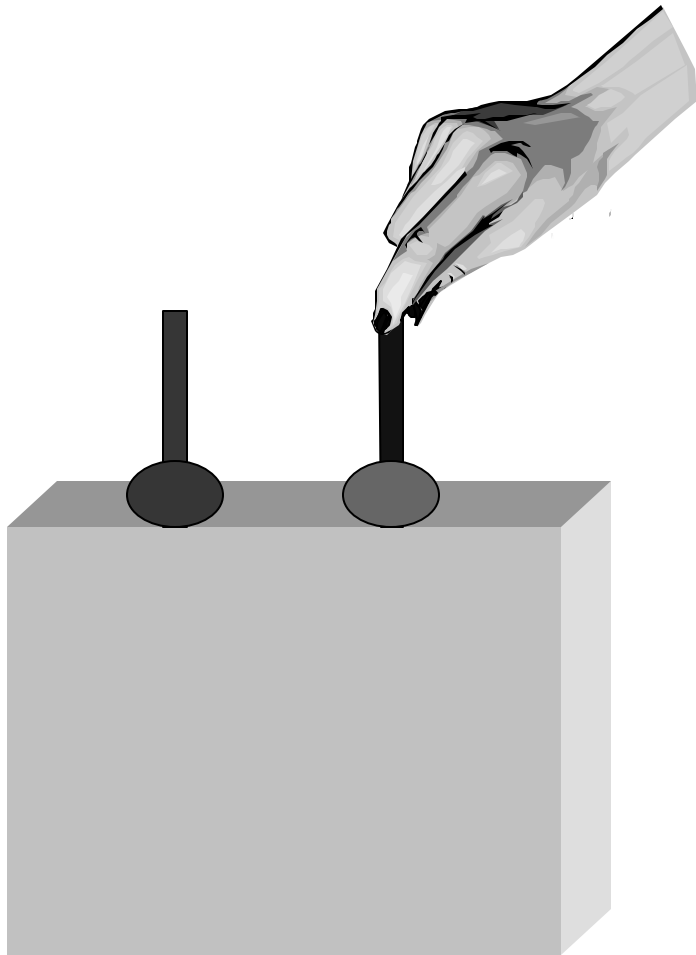

Observations & Interventions

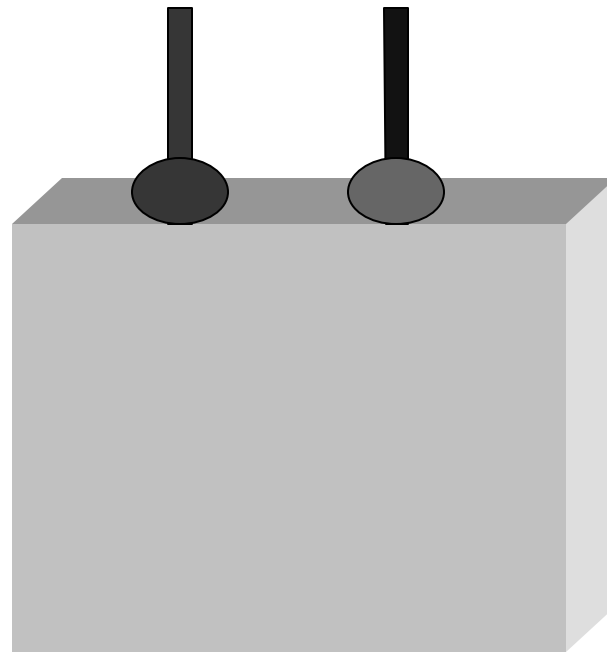

Interventions Only

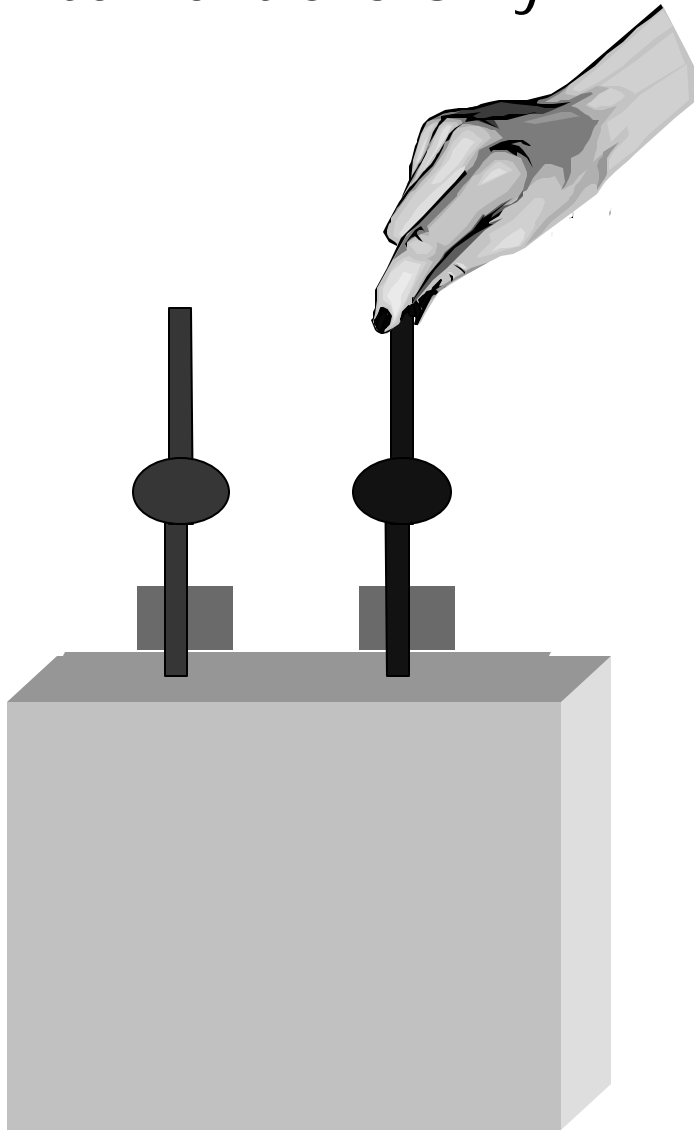

Observations & Interventions

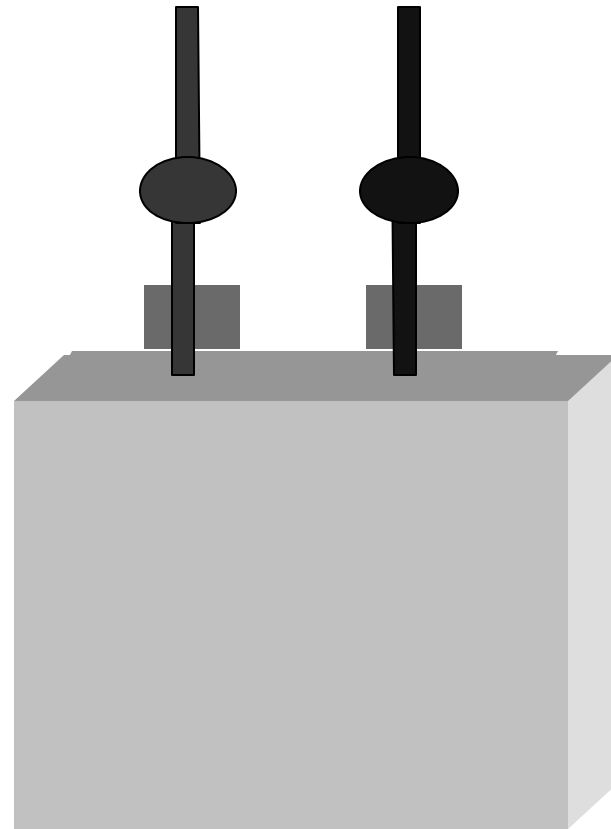

Interventions Only

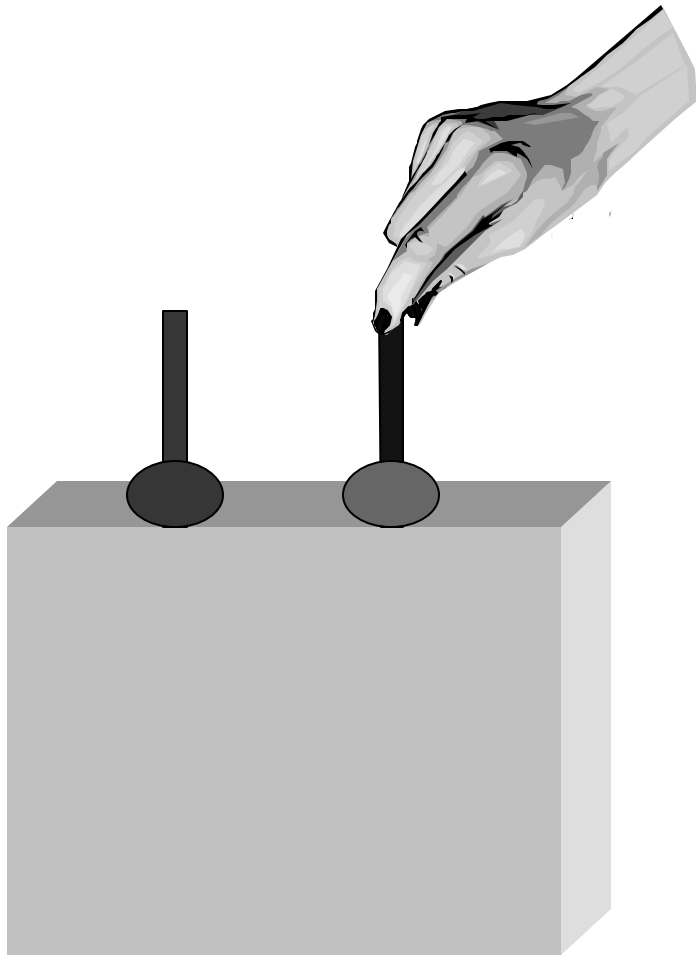

Observations & Interventions

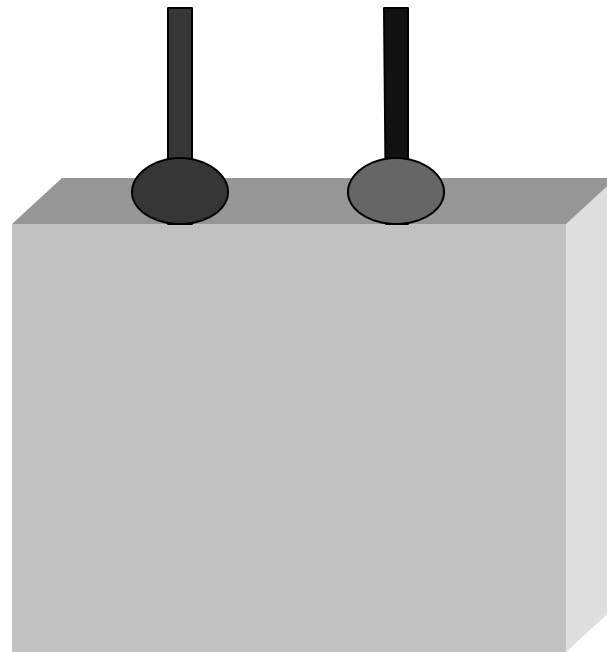

Interventions Only

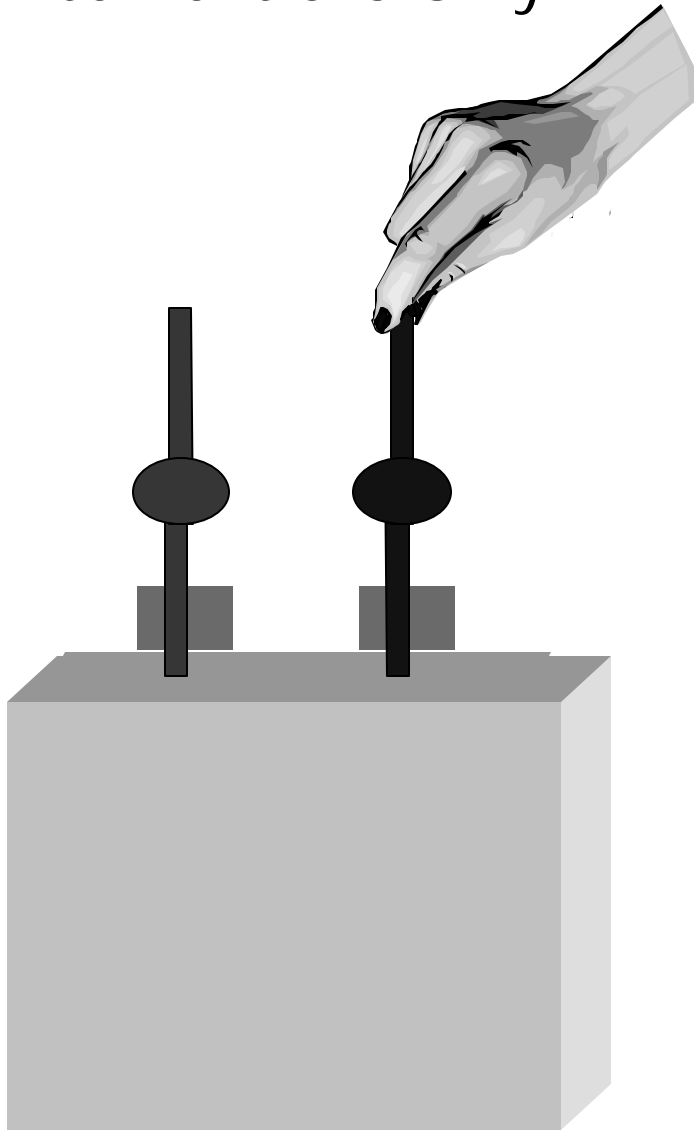

Observations & Interventions

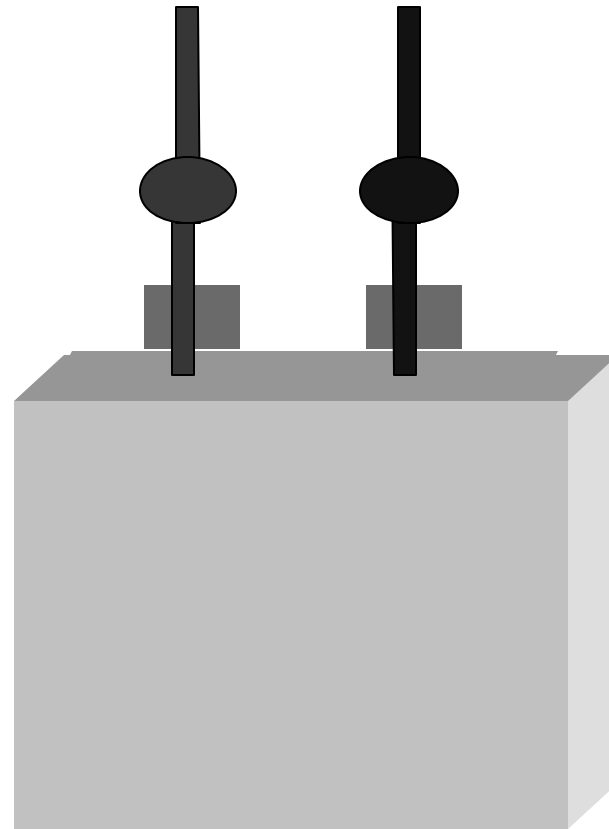

Interventions Only

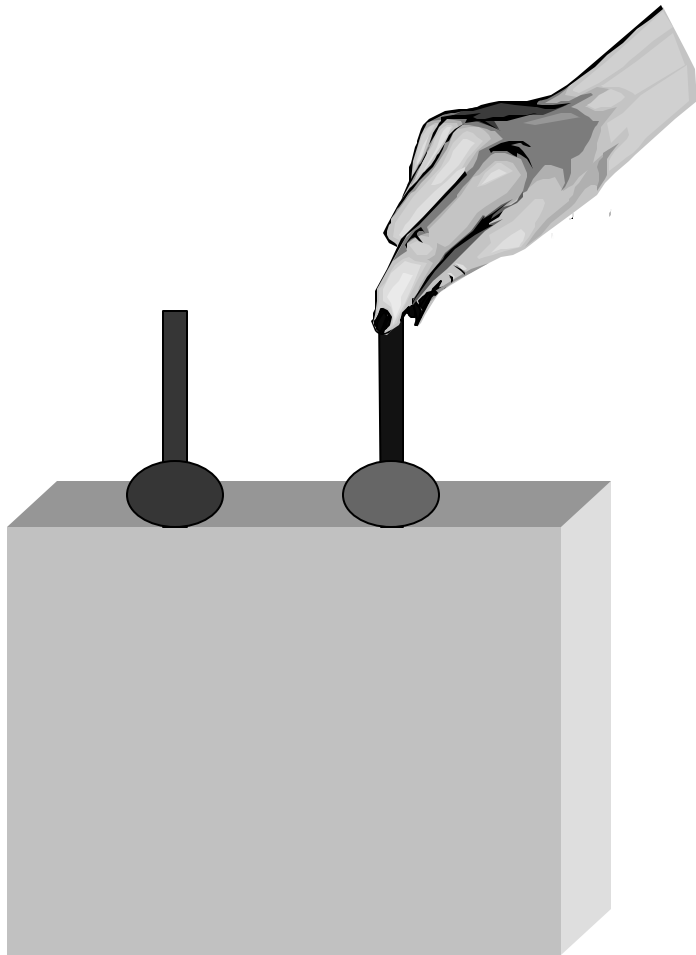

Observations & Interventions

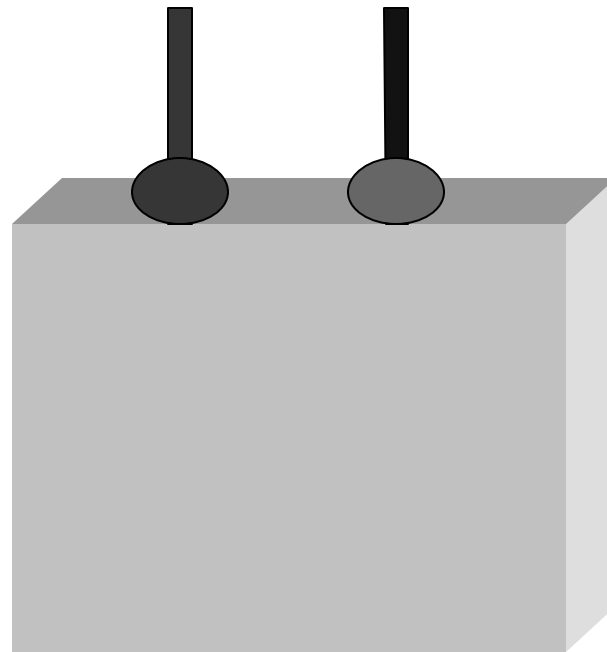

Interventions Only

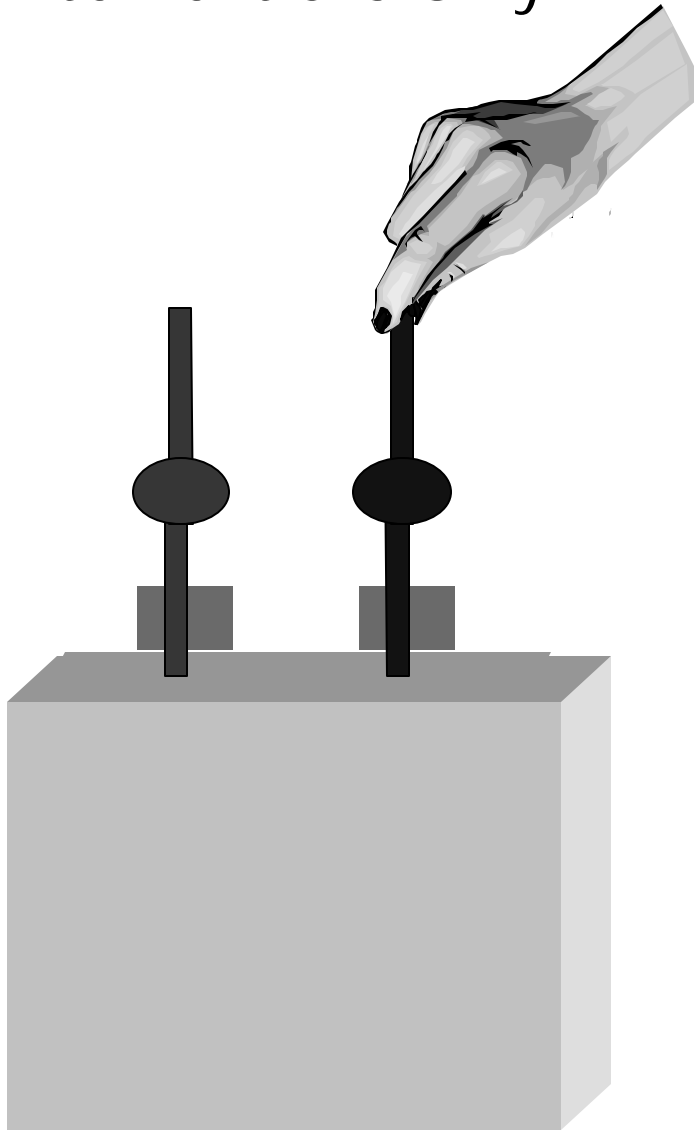

Observations & Interventions

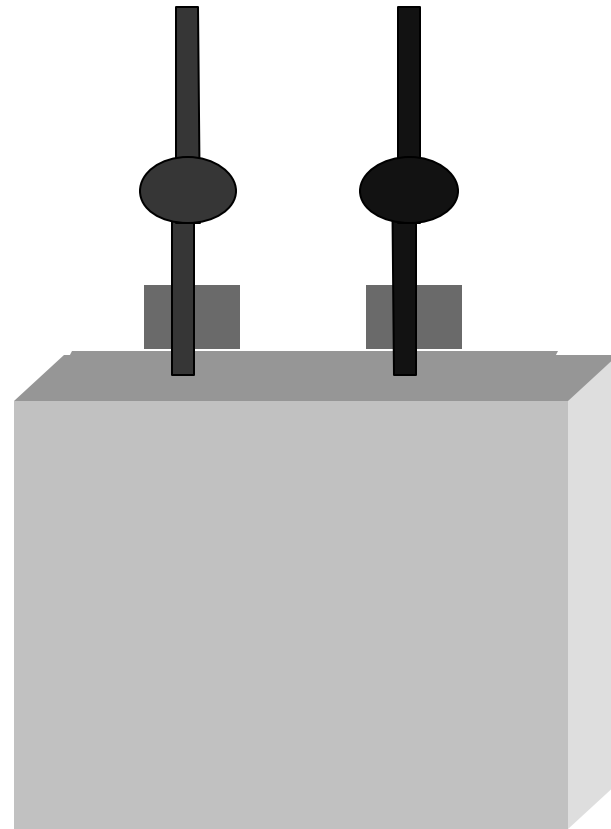

Interventions Only

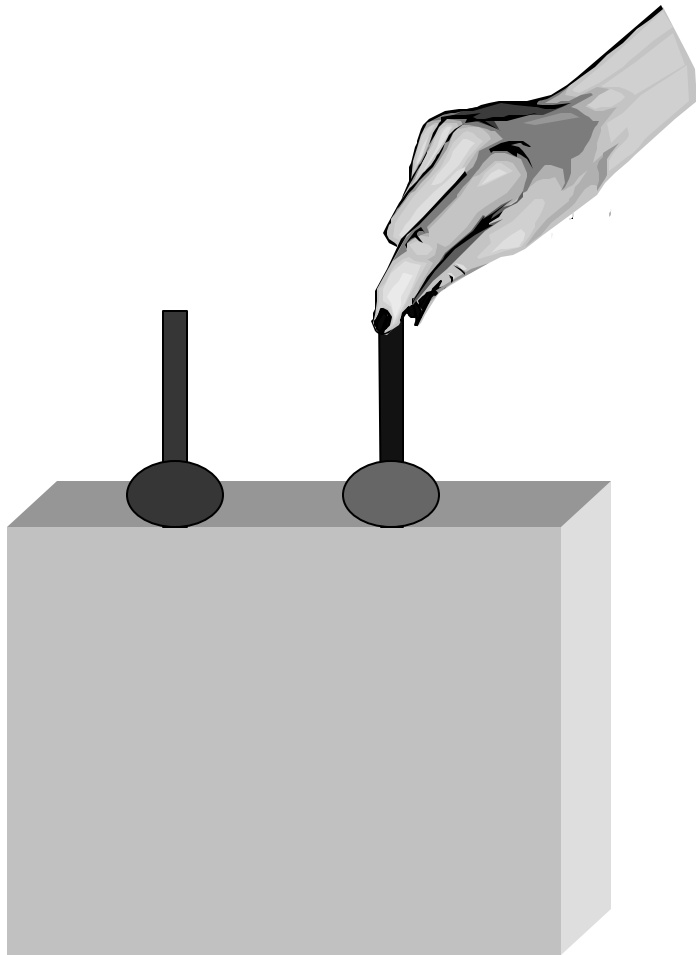

Observations & Interventions

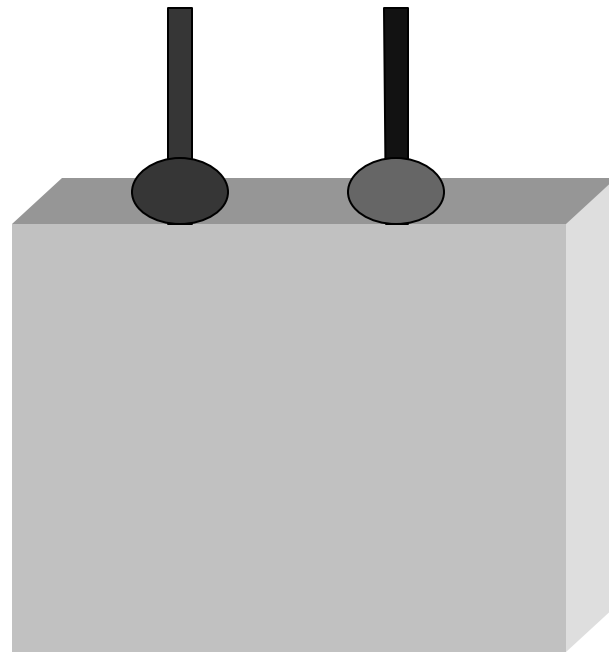

Interventions Only

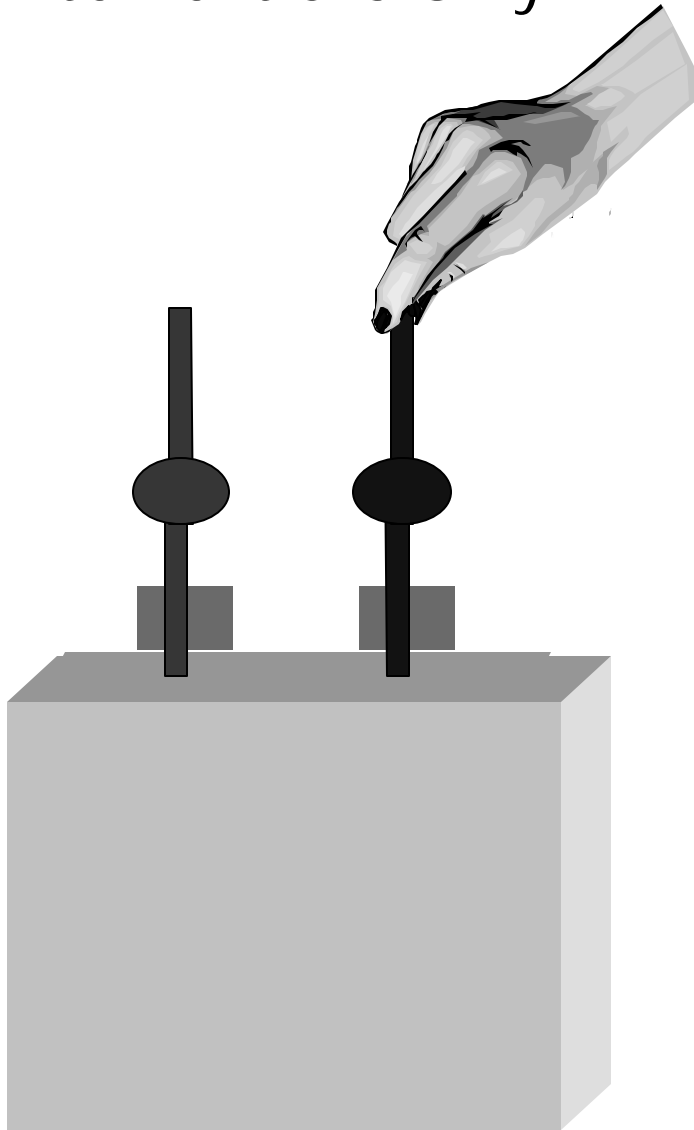

Observations & Interventions

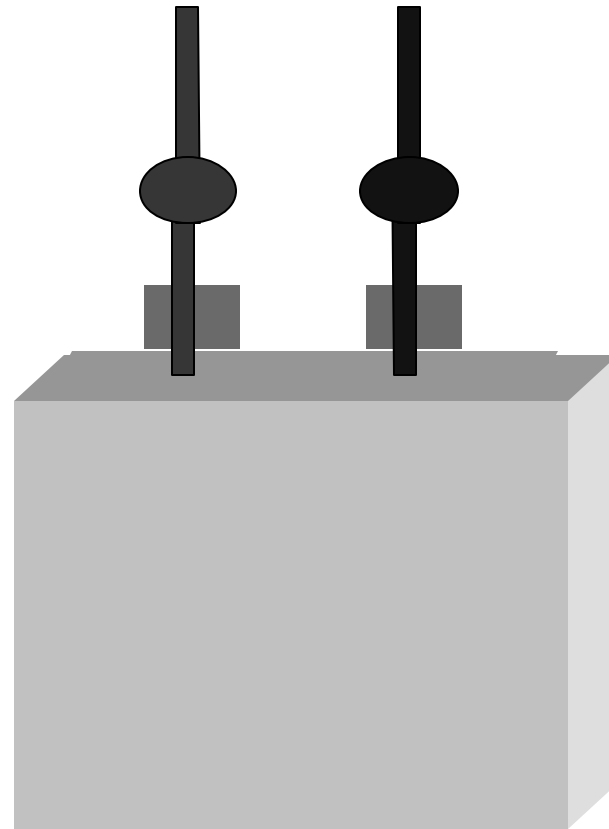

Interventions Only

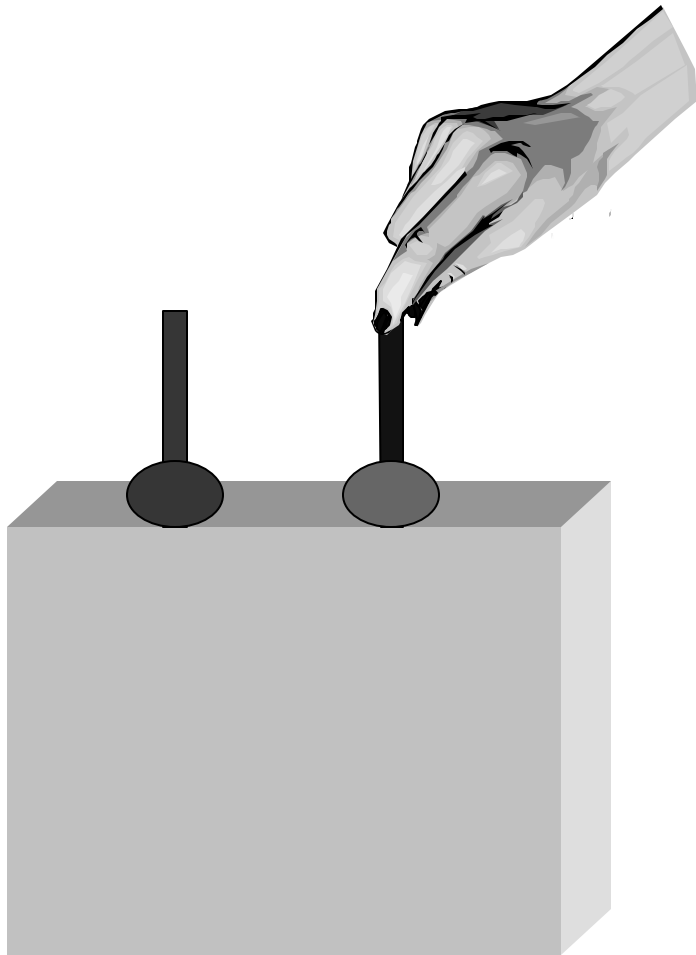

Observations & Interventions

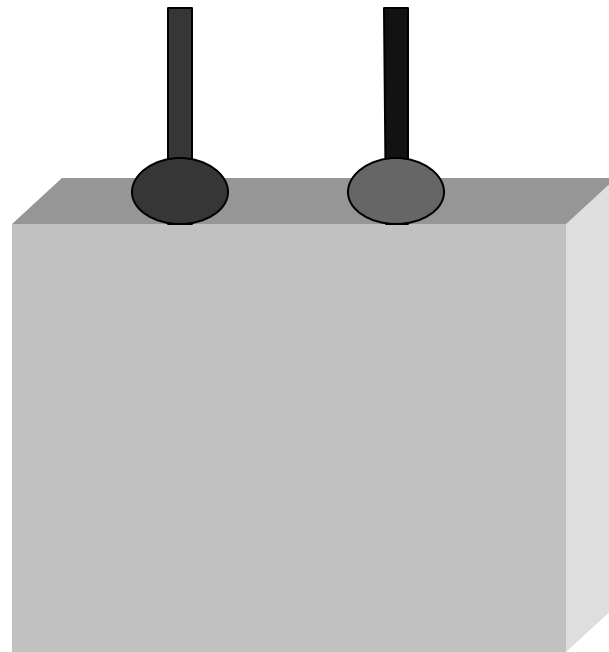

Interventions Only

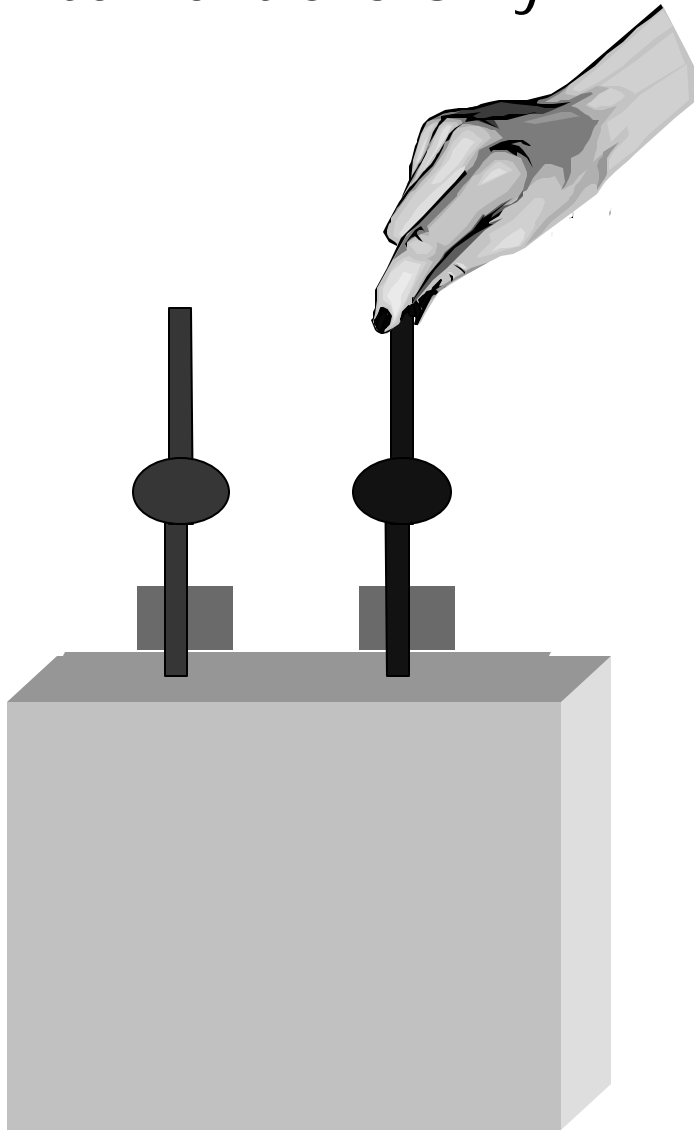

Observations & Interventions

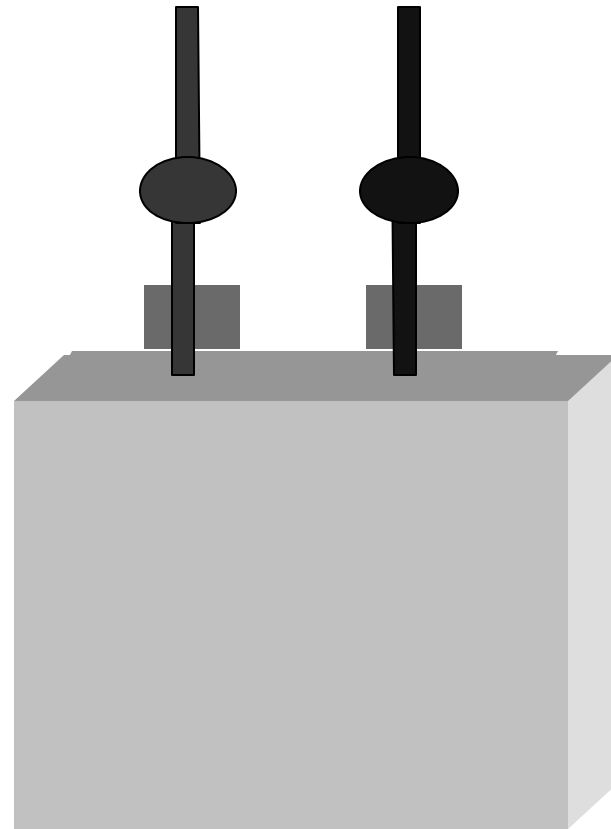

Interventions Only

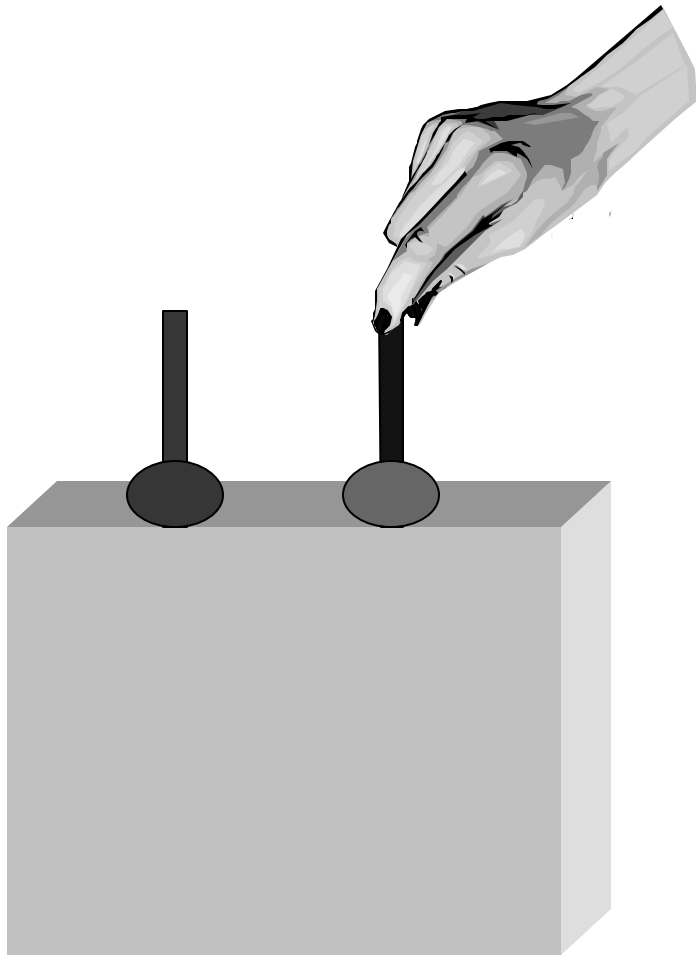

T. Kushnir, Few 2005

Observations & Interventions

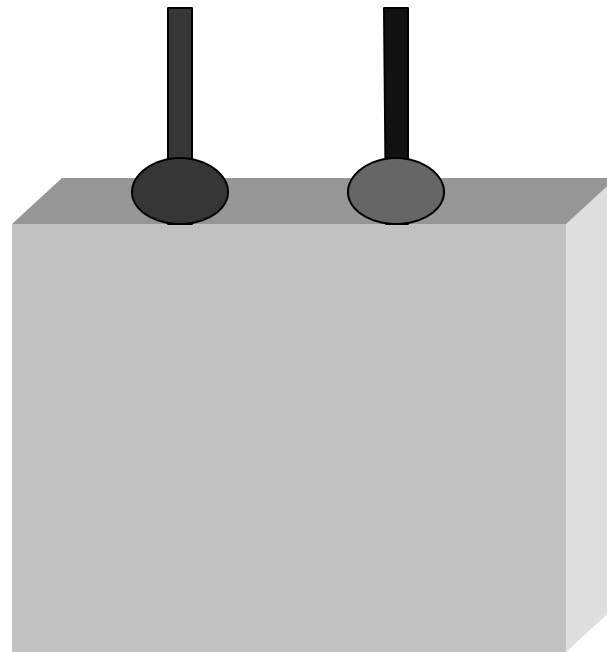

Gopnik et al, 2004

Interventions Only

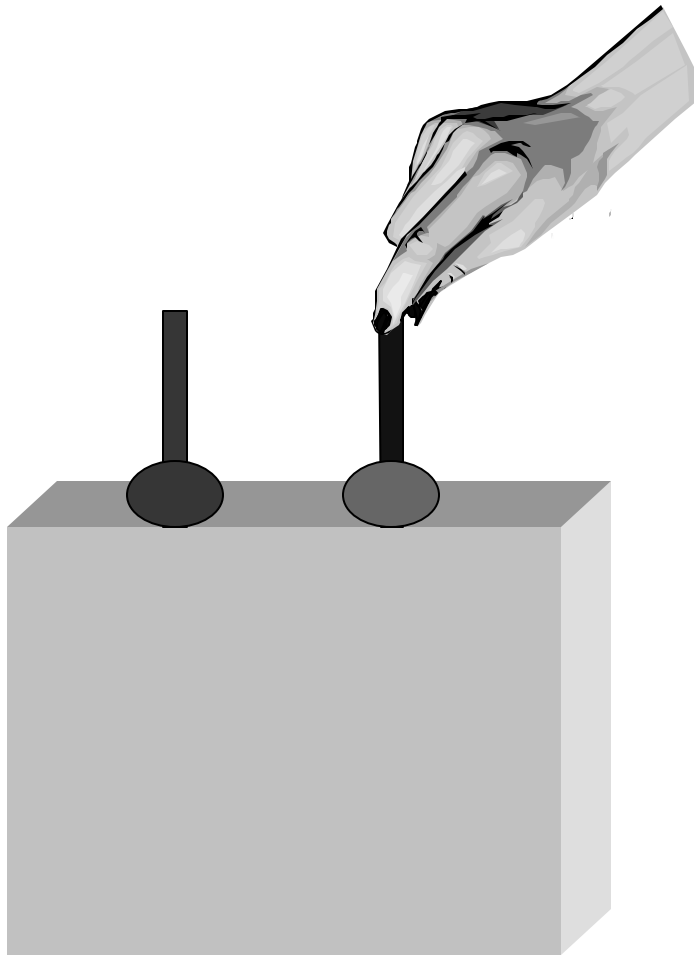

Observations & Interventions

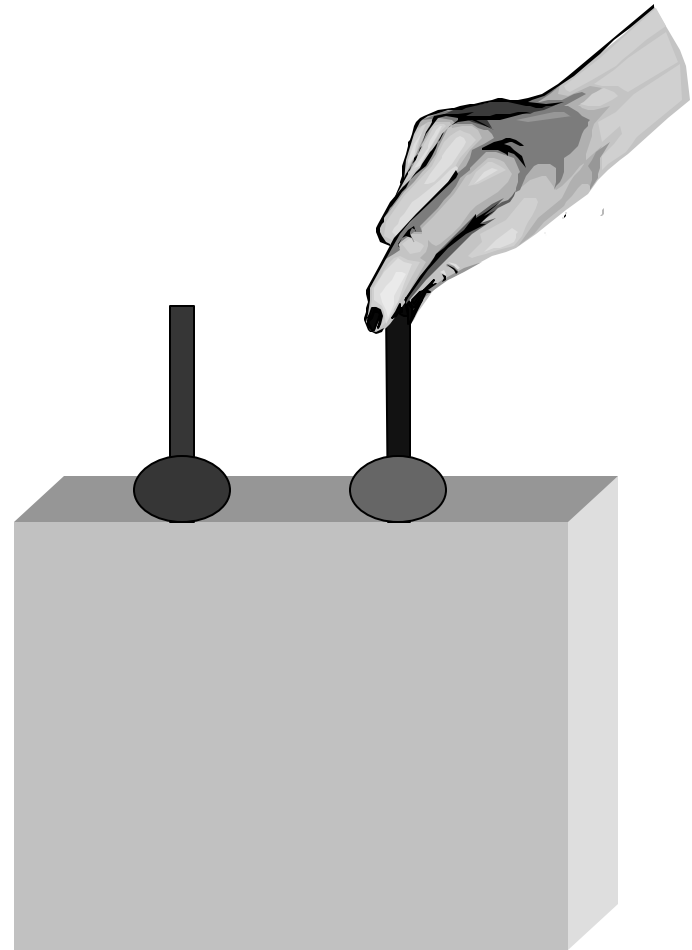

Interventions Only

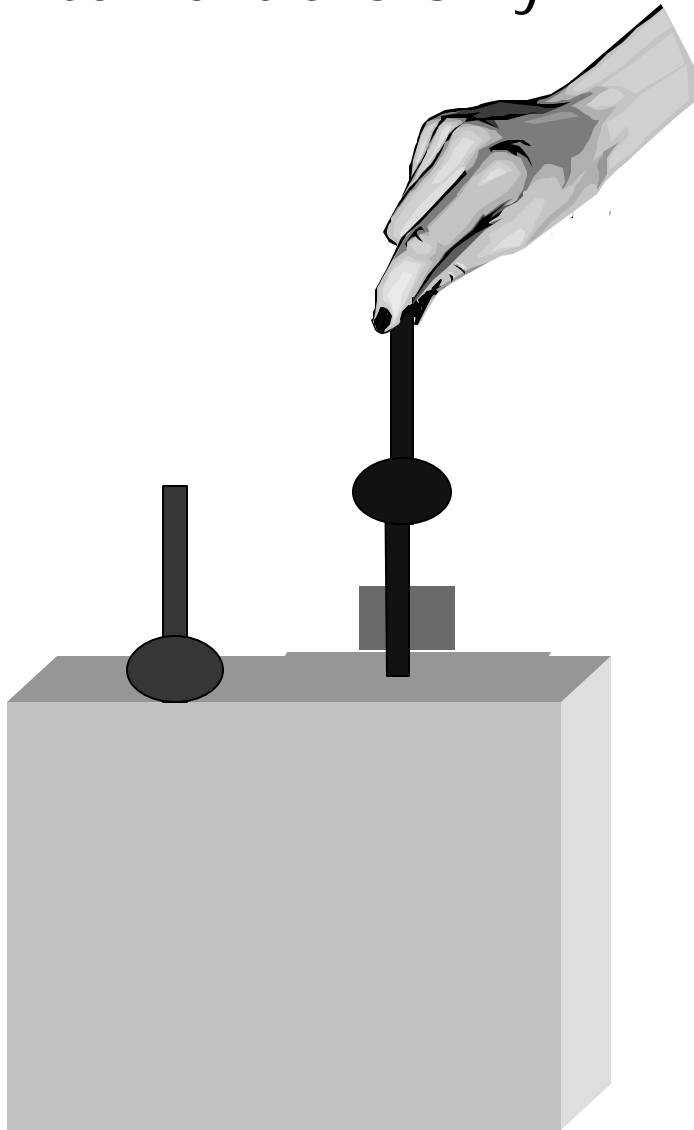

Observations & Interventions

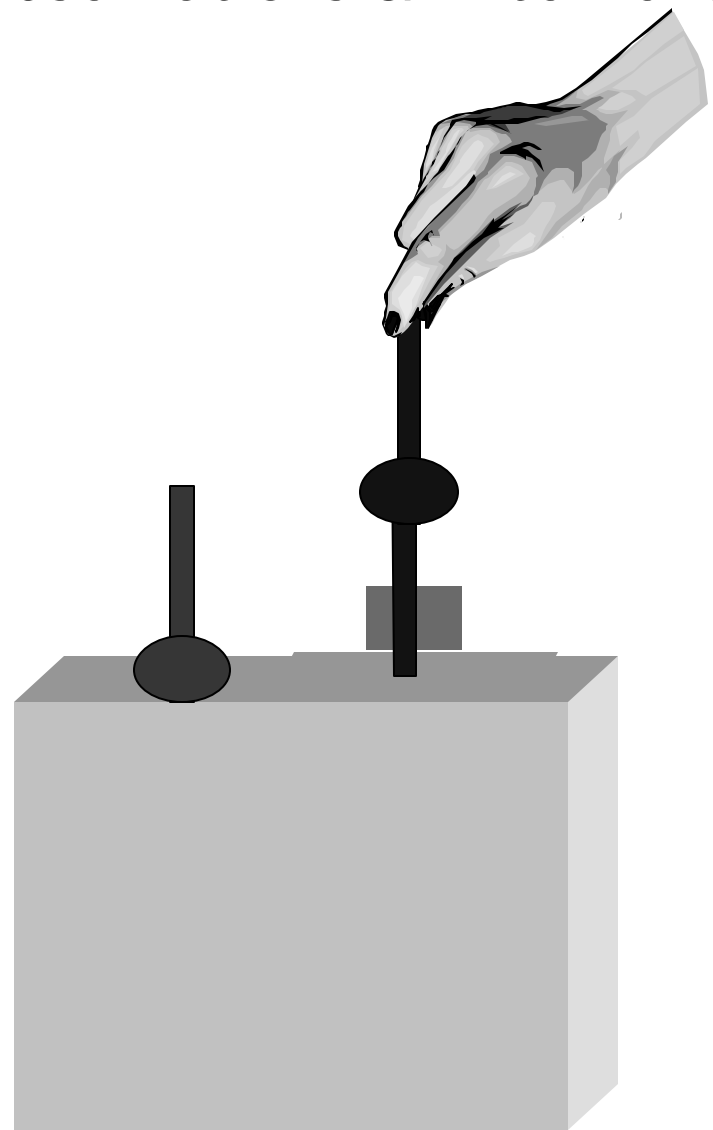

Interventions Only

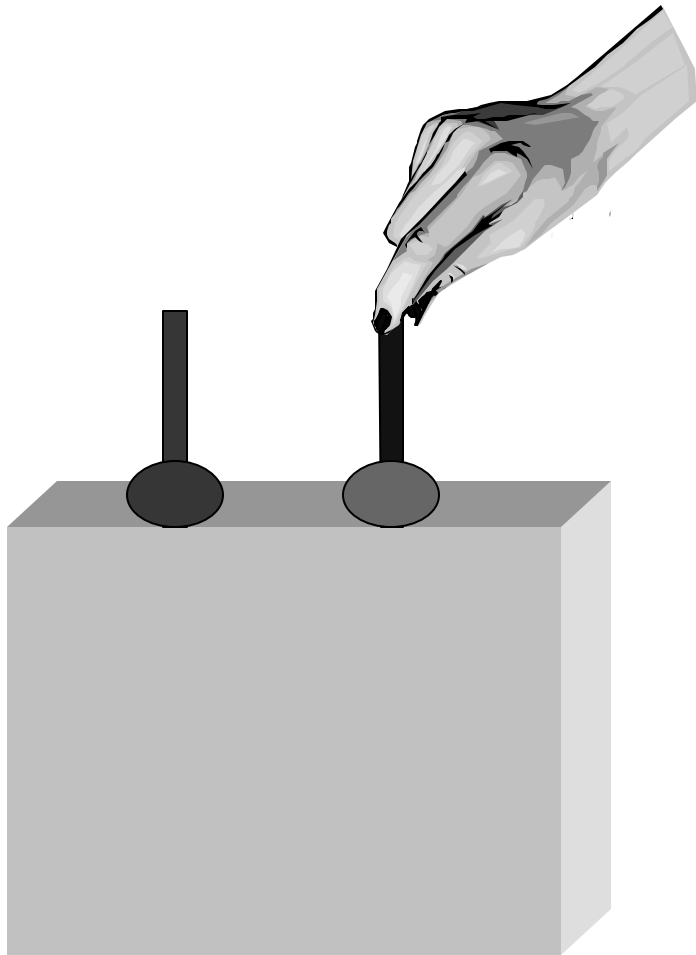

Observations & Interventions

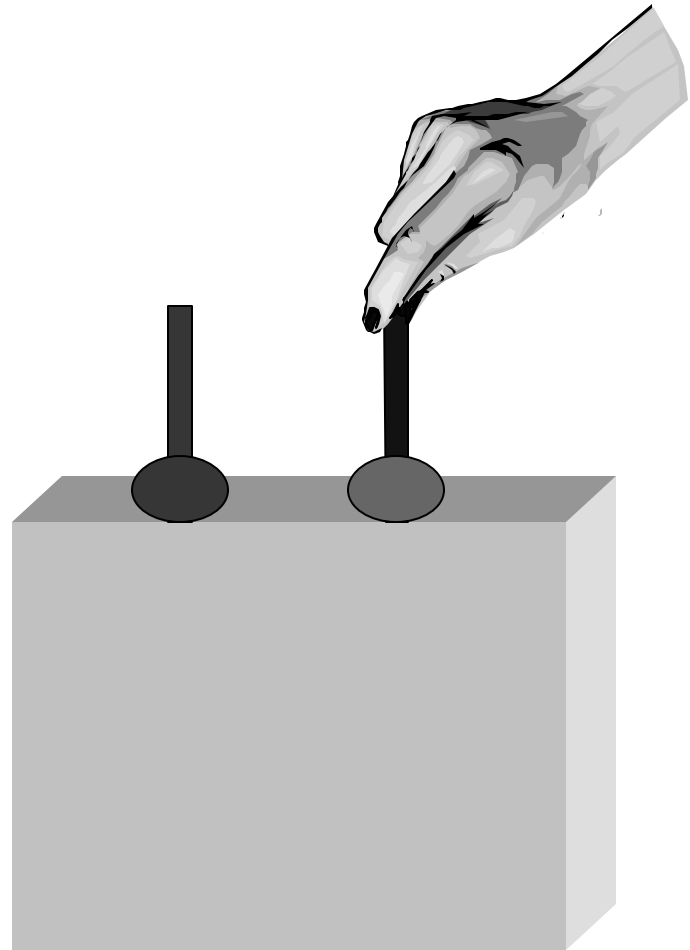

Interventions Only

Intervene on B: A & B – 5 times
Intervene on B: B alone – 1 time

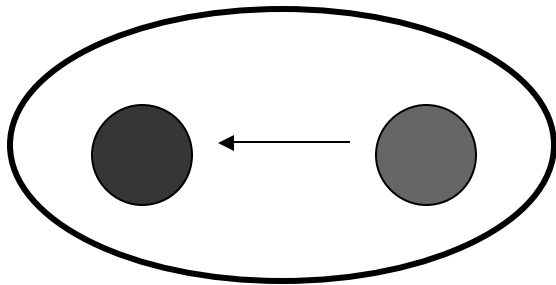
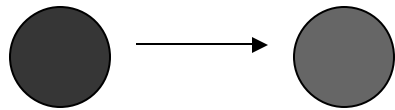

Observations & Interventions

A & B – 5 times
Intervene on B: B alone – 1 time

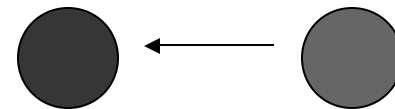
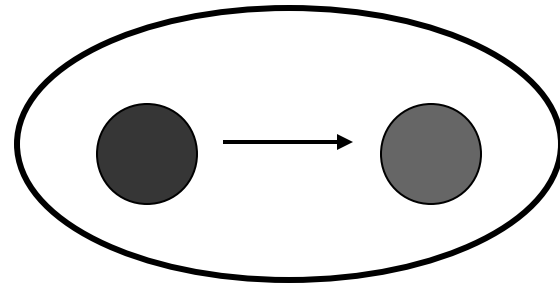

Part 1: Conclusion

- Both adults and children
 - Distinguish observations from interventions
 - Integrate evidence from both sources of data to learn causal structure.
 - Results (from yesterday) of complex causal structure learning in both children and adults are not possible without the ability to do both of the above.

Part 2: Intervention Source

- Does the source of interventions – one's own or someone else's - matter?
 - Study 1 (Children): How do causal strength judgments interact with intervention source?
 - Study 2 (Adults): How is structure learning affected by intervention source?
 - Study 3 (from yesterday): Children's own spontaneous interventions in play.

Intervention Source & Probability Judgment



Block A: $P=2/3$



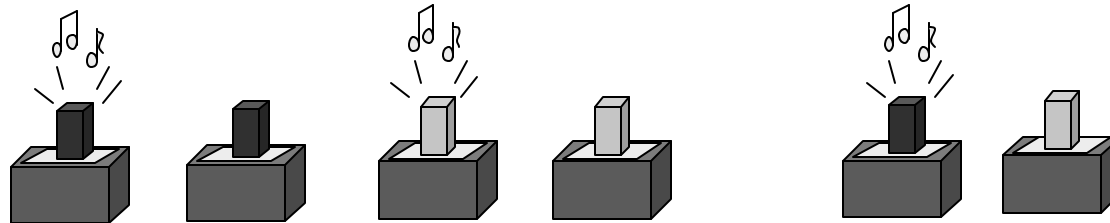

Block B: $P=1/3$



Intervention: Experimenter \longrightarrow Child \longrightarrow

Observation: Experimenter \longrightarrow

1. Intervention Question: "Pick the best one and make the toy go."
2. Hidden Cause Question: "Which one has more stuff inside?"

 Block A: P=2/3
 Block B: P=1/3

Sequence of Events

Percentage of 4-year-olds
 (Mean age 4;2) choosing
 Block A (N=19)

Non-conflicting
Intervention

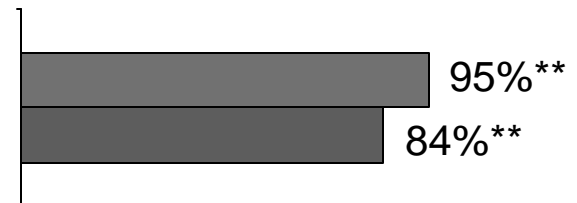
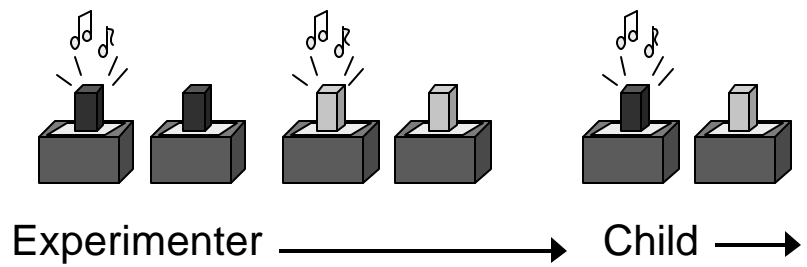

Observation 1

Ambiguous
Intervention

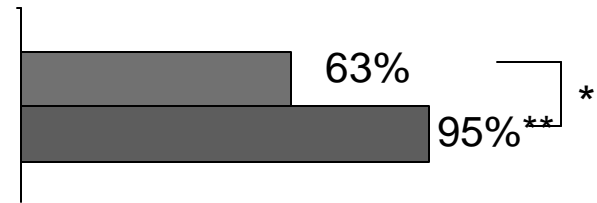
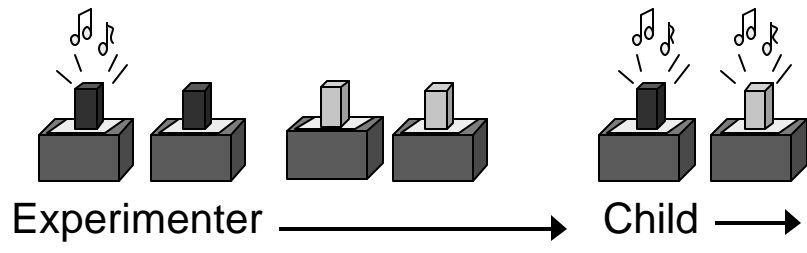

Observation 2

Conflicting
Intervention

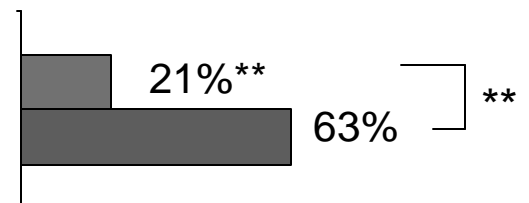
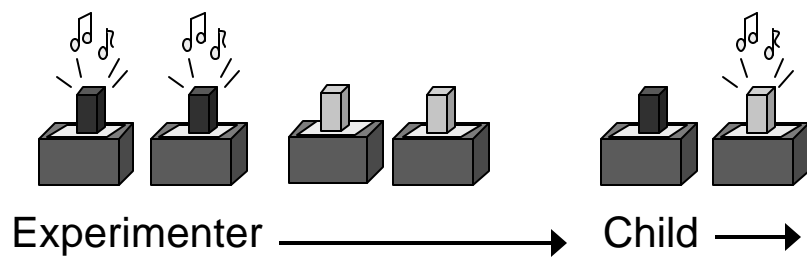

Observation 3

Intervention Source & Probability Judgment

- When observing the experimenter intervene, probabilistic strength = more hidden stuff.
- When their own interventions conflicted with the overall probabilities, the object that worked for them = more hidden stuff.
- Is this because children believe their own interventions are more likely to be unconfounded?
- What if their own interventions are explicitly confounded? Will they still show a preference?

Intervention Source and Confounding

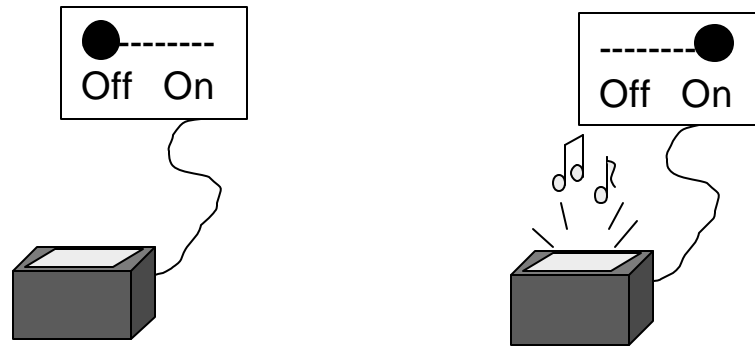

Intervention Source and Confounding

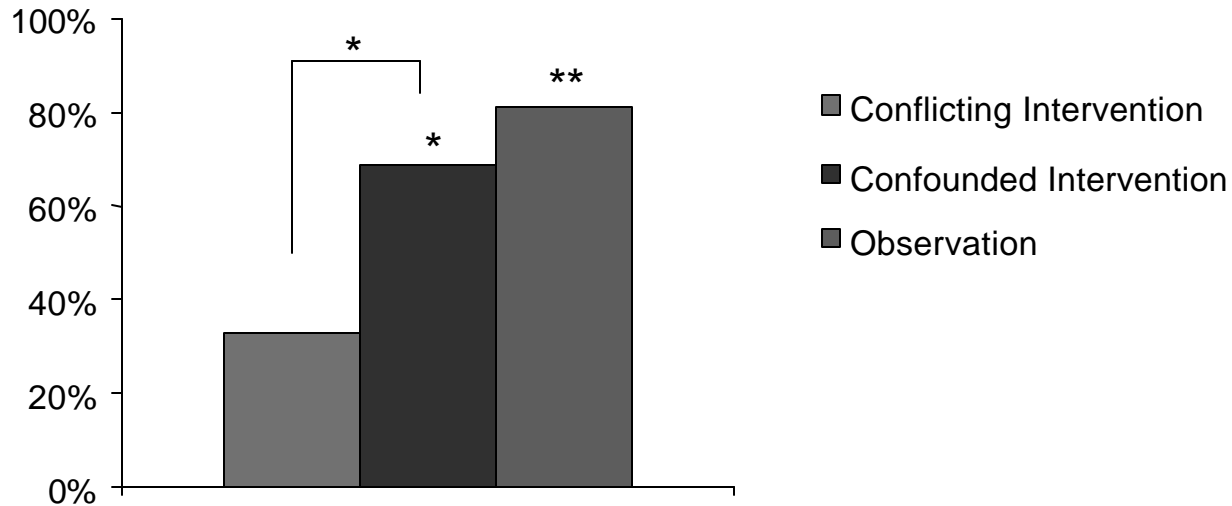
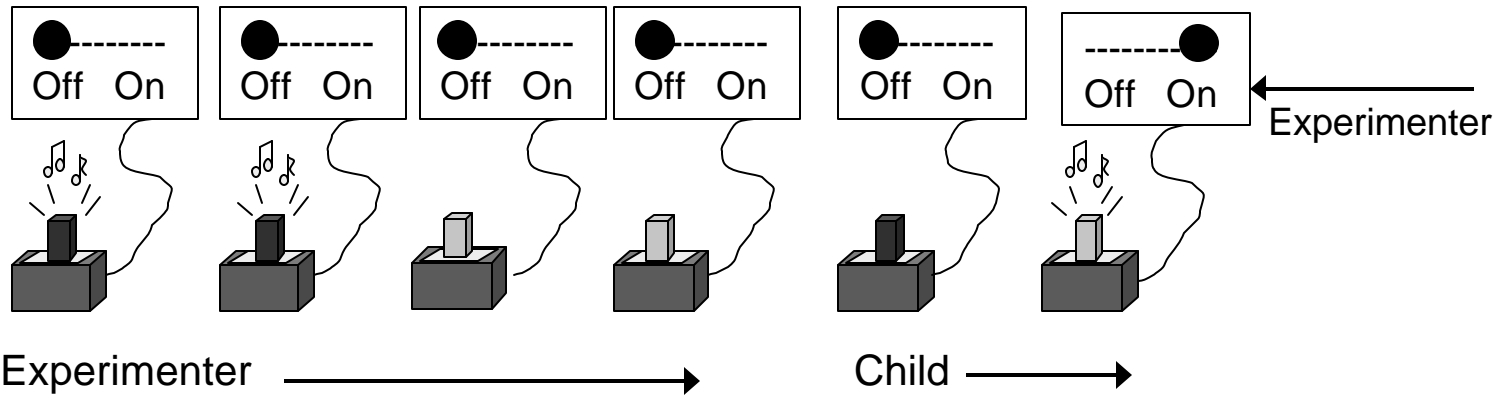

“Which one has more stuff inside?”

Intervention Source and Structure Learning

- The lab of “Dr. Science” (Sobel & Kushnir, in press).
 - The learning environment:
 - Colored lights and sensors
 - No spatio-temporal information
 - Generative & preventative interventions.
 - Three yoked conditions
 - Own Intervention
 - Observation of Intervention
 - Forced Intervention

Intervention Source and Structure Learning

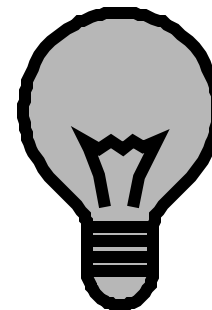
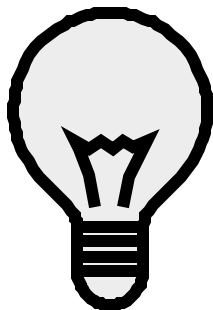
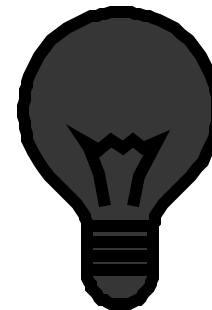
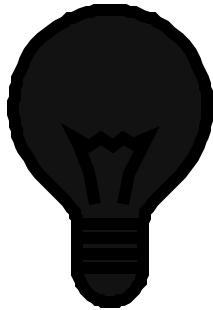

Intervention Source and Structure Learning

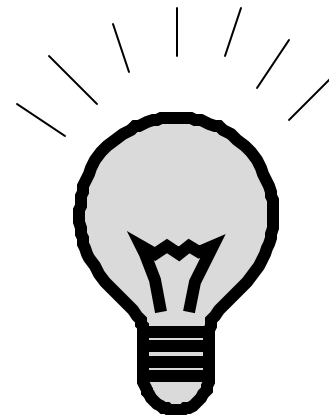
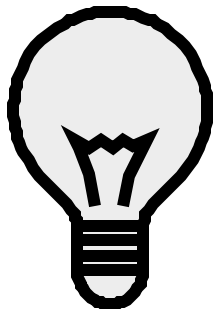
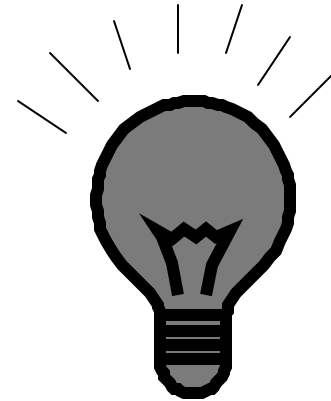
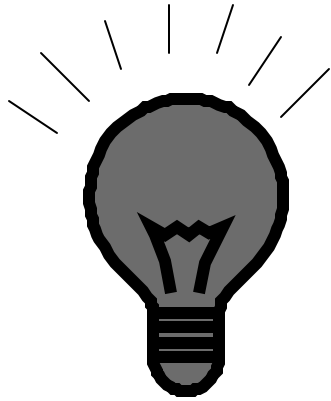

Intervention Source and Structure Learning

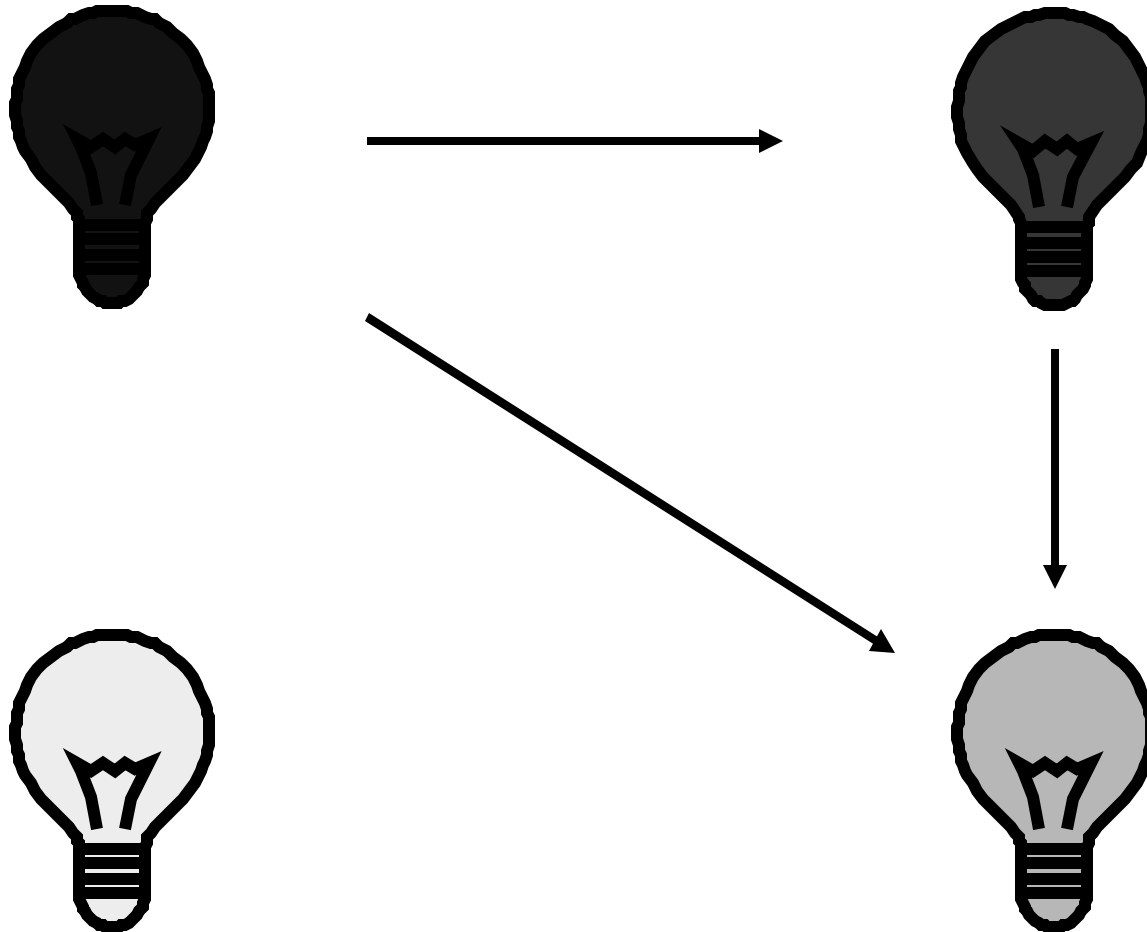

Intervention Source and Structure Learning

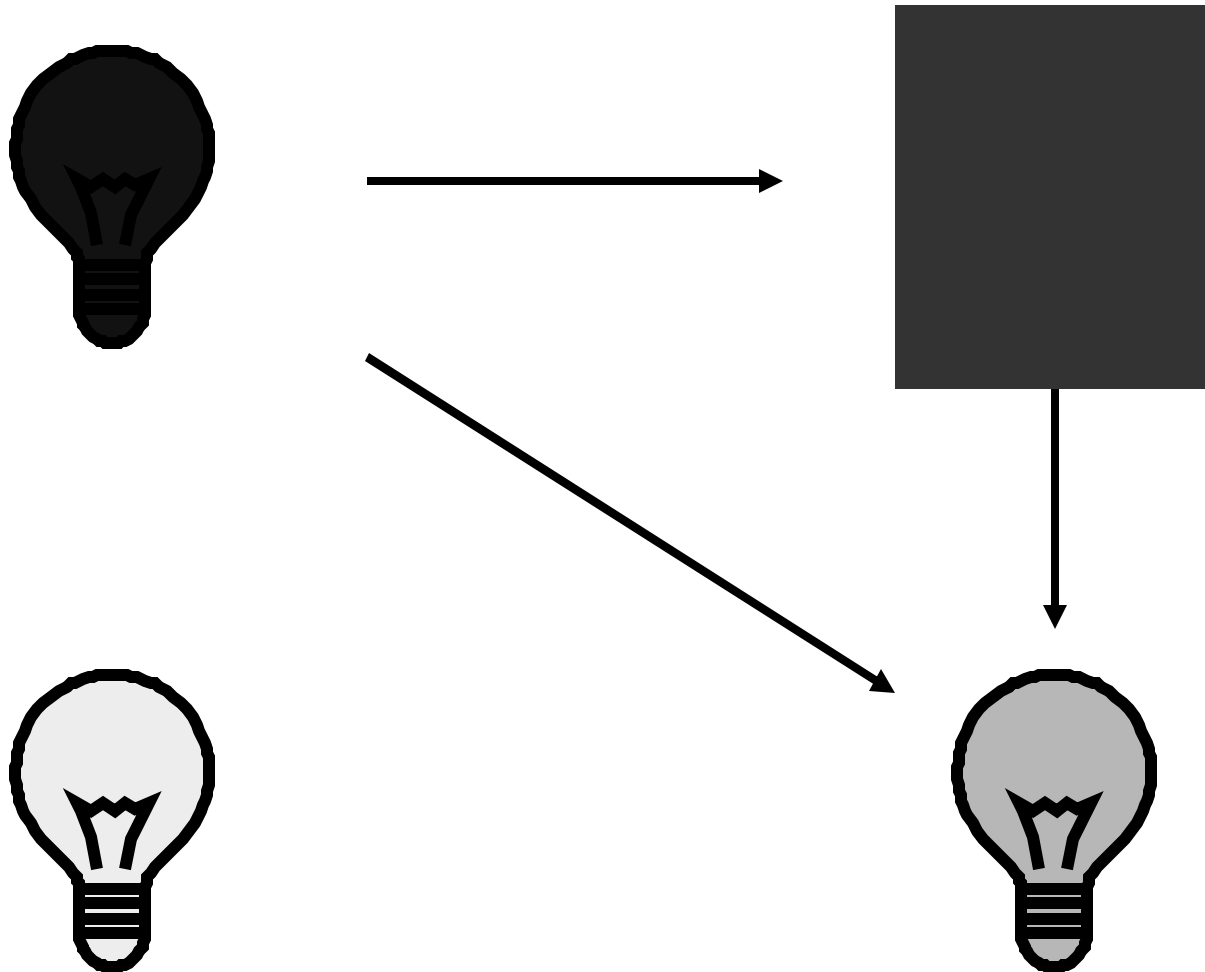

Intervention Source and Structure Learning

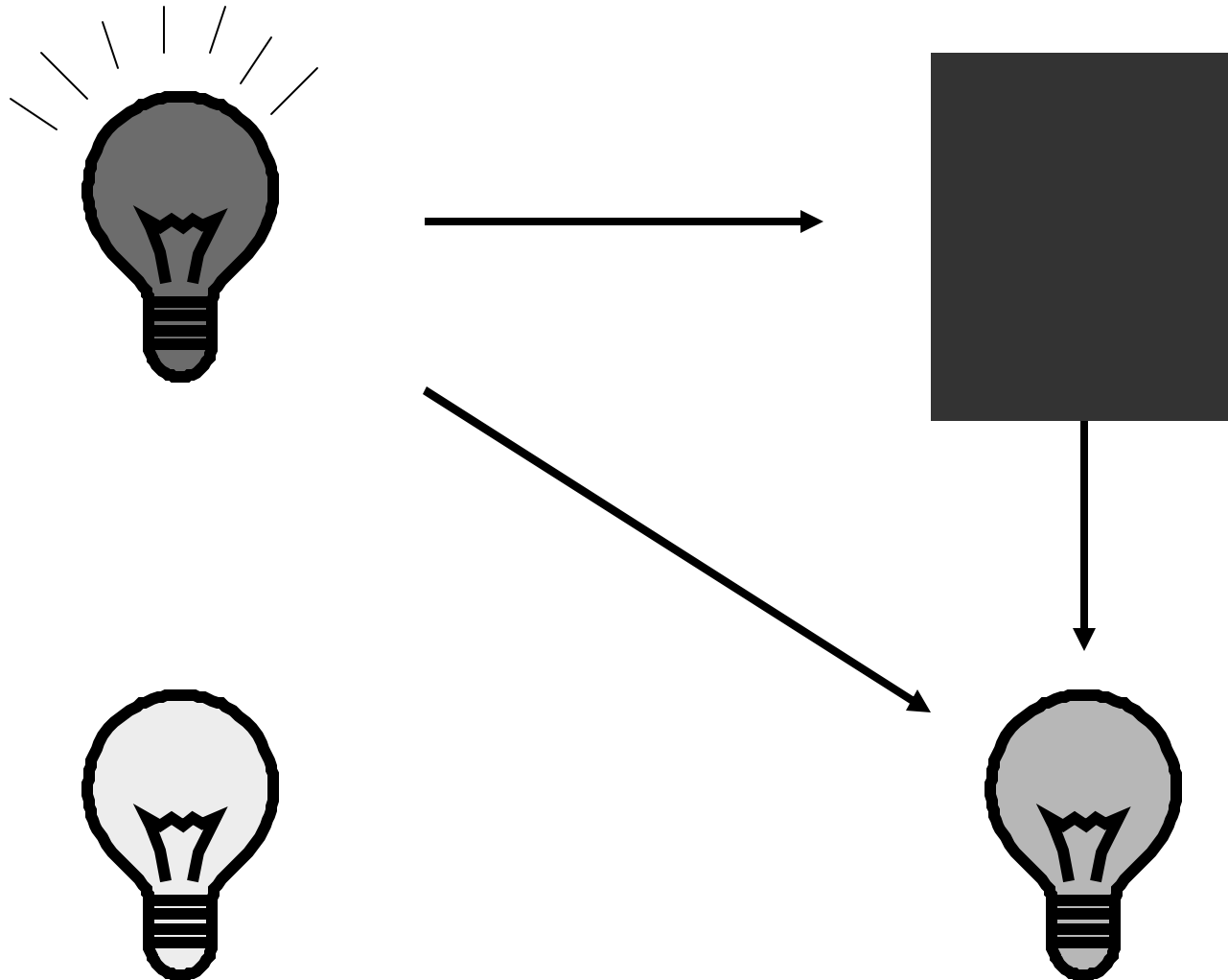

Intervention Source and Structure Learning

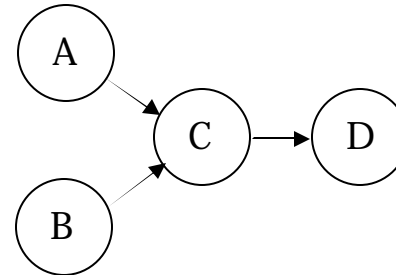
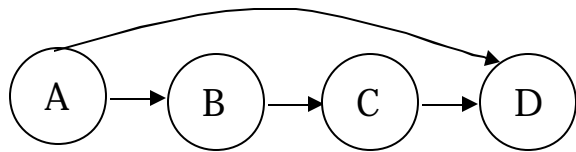
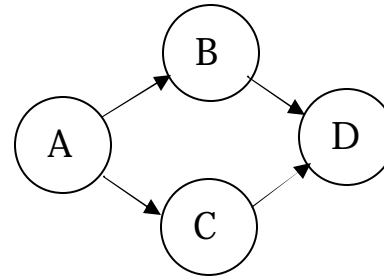
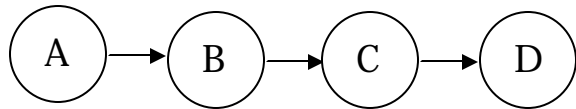

- **Results: In the Own Intervention condition...**
 - Accuracy significantly higher
 - Significantly more participants learned structure perfectly
 - Performance correlates with the number of critical interventions made.

Part 2: Conclusion

- There are several ways in which one's own interventions may be critical for causal learning.
 - Four-year-olds give preference to evidence from their own interventions over probabilities (because they believe those interventions are unconfounded).
 - Adults learn causal structure best when deciding how to intervene (because it enables them to pay attention to critical interventions).
 - Adults (from Dr. Science) and children (from yesterday) are capable of spontaneously generating appropriate interventions for structure learning through play.

Part 3: Prior Knowledge

- By preschool, children have a substantial amount of knowledge about the world.
- Knowledge is organized into domain-specific theories.
 - Folk Physics (Spelke et al, 1992)
 - Folk Biology (Gelman & Wellman, 1991)
 - Folk Psychology (Wellman, 1990)
- What role does existing knowledge play in learning new causal relations?
 - Integrating prior knowledge: Base rates
 - Overriding prior knowledge: Domain specific assumptions

Integrating Prior Knowledge

- Do preschool children pay attention to base rates?
- Backwards Blocking task
 - Objects that make the toy go are “Blickets”
 - Blickets are either rare (1/10) or common (9/10)

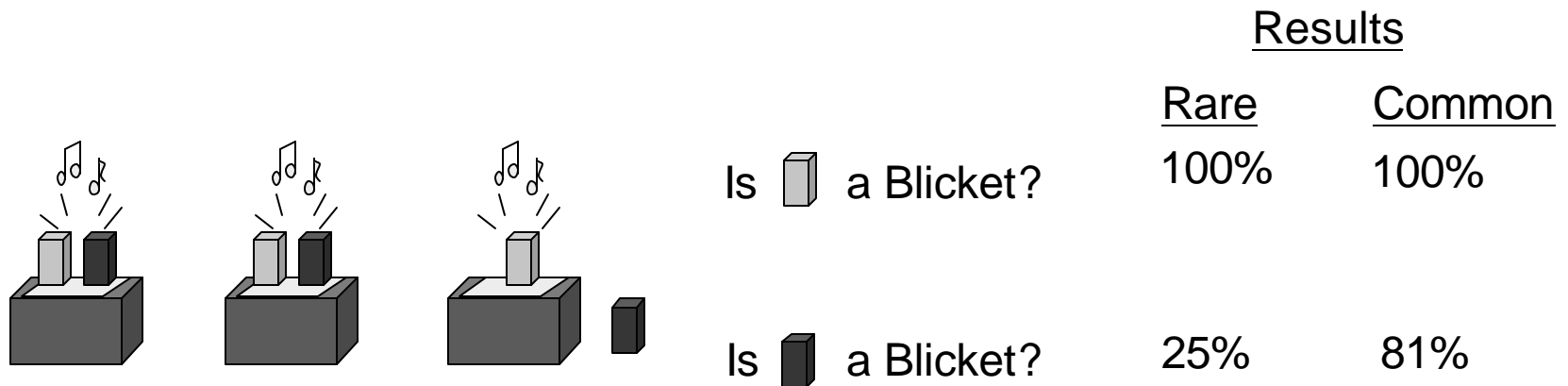

Prior knowledge about base rates affects children's inferences about ambiguous causes

Overriding Prior Knowledge

- Children's ability to make inferences about patterns of dependence and independence (i.e. "screening off") is *domain independent*. (Schulz & Gopnik, 2004)
- Are children's causal inferences restricted by domain-specific knowledge? Can they learn a new causal relation that overrides existing domain knowledge?

Overriding Prior Knowledge

- Children's physical knowledge: causal relations constrained by time and *space* (billiard balls).
- Giving children mechanism information allows them to learn causal relations in the absence of **spatial cues**. (Bullock et al, Schultz)
- Can they use patterns of probability, without mechanisms, to override spatial cues?

Overriding Prior Knowledge: Spatial Contiguity



- Initial intervention (no training): ALL children make contact between block and toy – strong preference for spatial contiguity.

Overriding Prior Knowledge: Spatial Contiguity

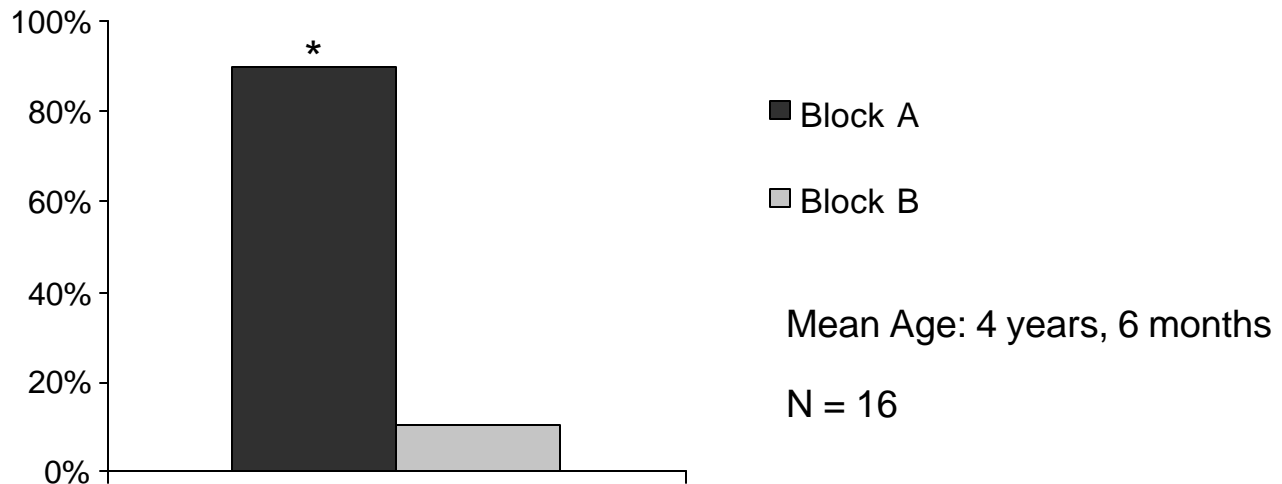
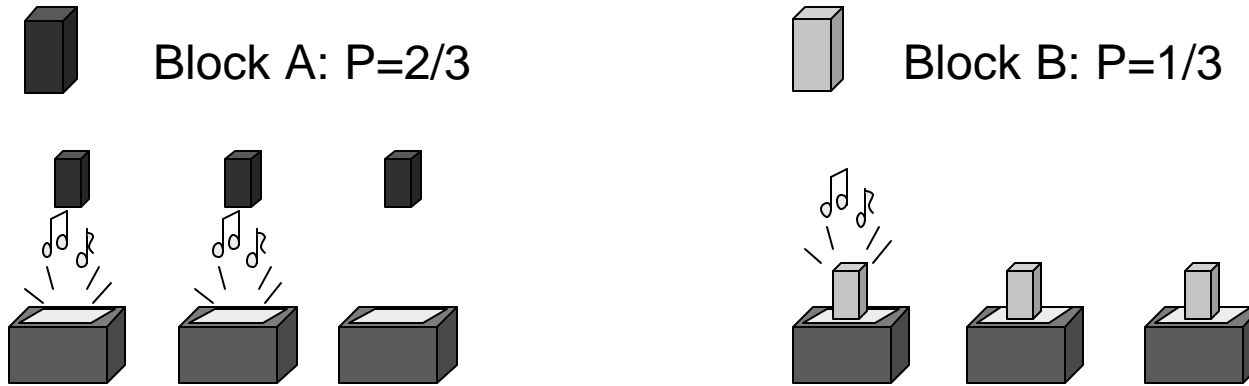

Causal Strength Question: "Which one works best?"

Overriding Prior Knowledge: Spatial Contiguity

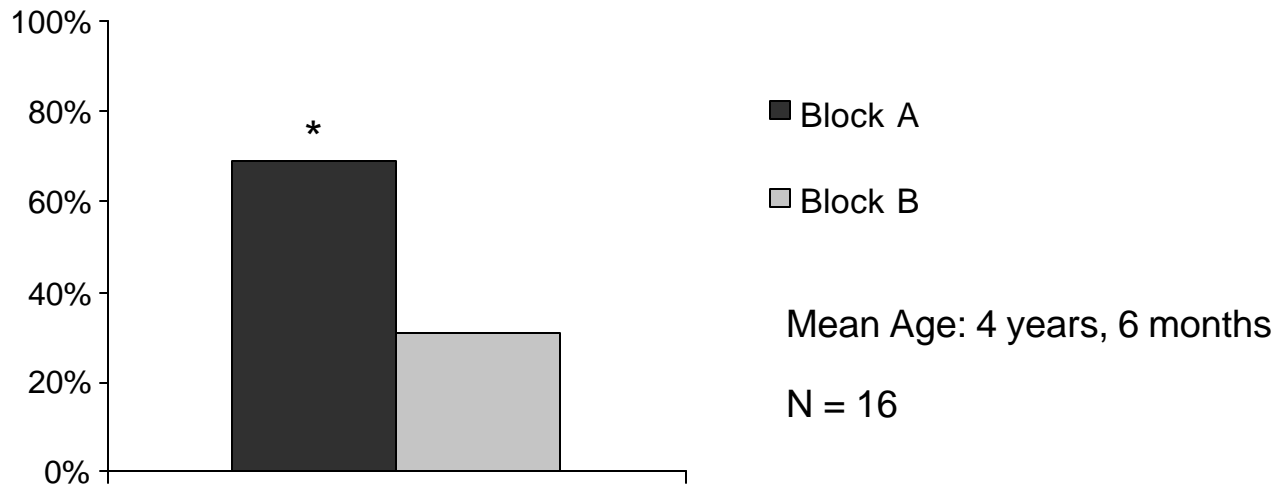
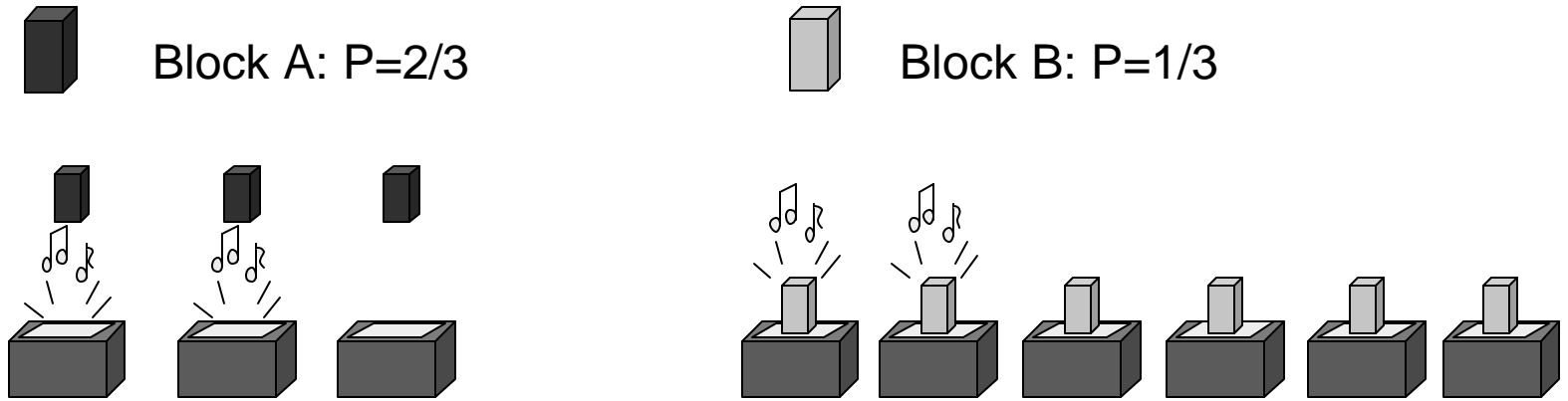

Causal Strength Question: "Which one works best?"

Overriding Prior Knowledge: Spatial Contiguity



- Initial intervention (no training): ALL children make contact between block and toy – strong preference for spatial contiguity.
- Final intervention: A significant number of children revised their initial intervention and held the new object over the toy.

Overriding Prior Knowledge Across Domains

Baseline condition

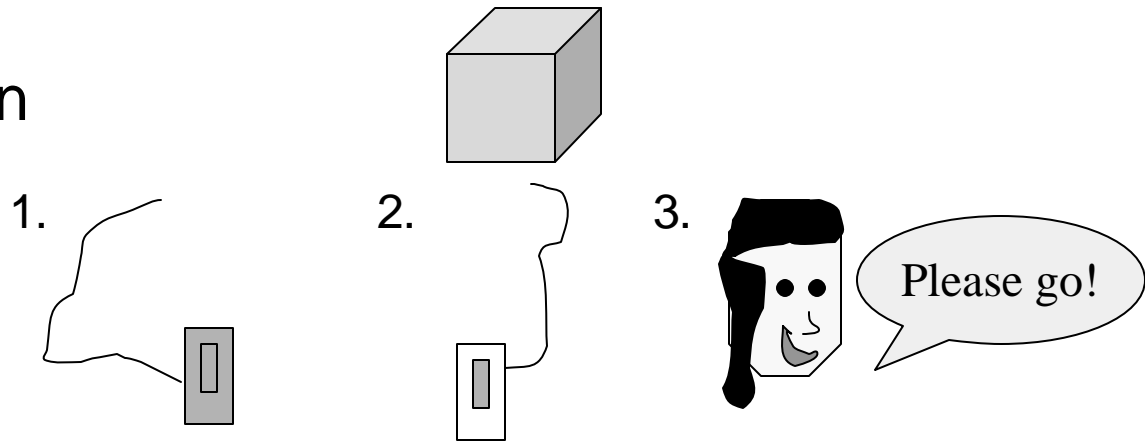

- Baseline intervention: ALL children choose the switches – strong preference for domain-appropriate causes.

Overriding Prior Knowledge Across Domains

Test condition

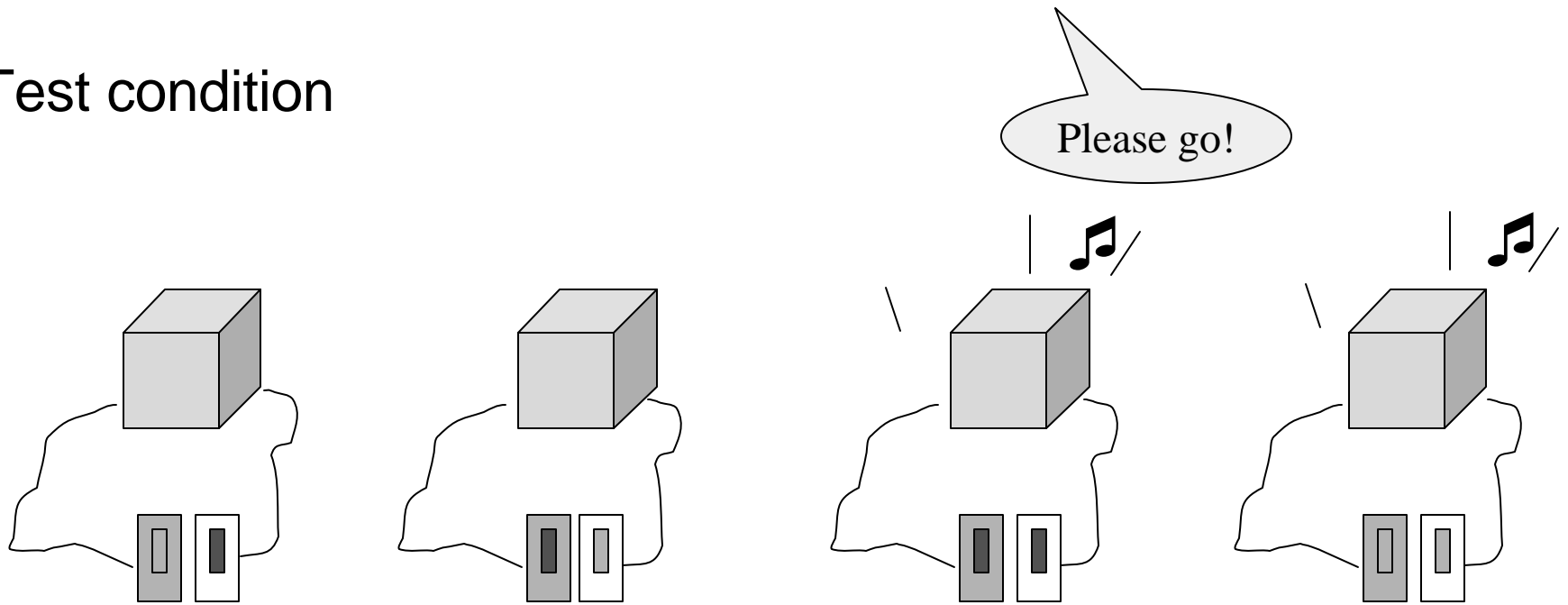

- Can you make the machine turn off?
- 75% said “please stop.”
- Results identical to within-domain screening off.

Overriding Prior Knowledge Across Domains

Transfer condition

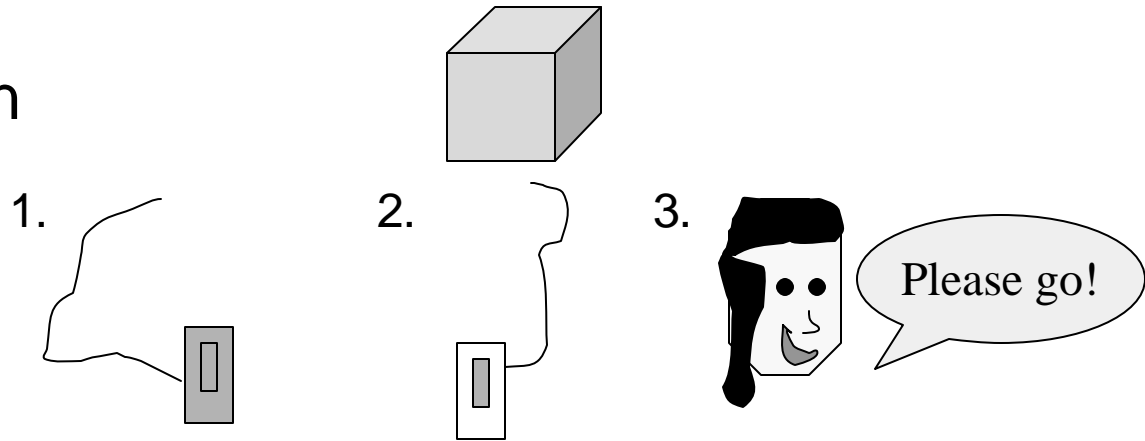

- Baseline intervention: ALL children choose the switches – strong preference for domain-appropriate causes.
- Transfer intervention: Most chose switches, but significantly more chose to say “please go” than at baseline.

Part 3: Conclusion

- Prior knowledge plays a significant role in learning new causal relations.
 - Children pay attention to base rates when making inferences about ambiguous causes.
 - Children also have strong preferences for domain-appropriate causal relations.
 - Children can override prior knowledge when faced with new evidence in the form of patterns of probabilities.



Summary

- Part 1: Both adults and children distinguish between interventions and observations when learning causal structure.
- Part 2: The source of intervention information influences causal learning.
- Part 3: Causal learning involves both integrating and overriding prior knowledge.

Future Directions

- Probabilities
- Determinism
- Active Learning
- Experimental design and intervention
- Integration with spatio/temporal information
- Explanation
- Bootstrapping and revision

Thank you

-  Block A: P=2/3
-  Block B: P=1/3

Sequence of Events

Percentage of 4- and 6-year-olds (Mean age 4;6 and 6;2) choosing Block A (N=36)

Non-conflicting
Intervention
Observation 1

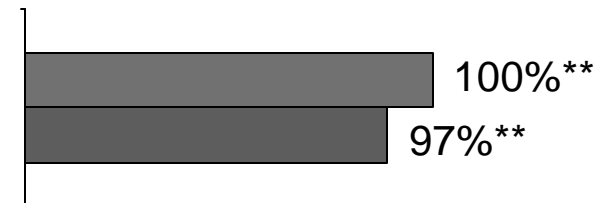
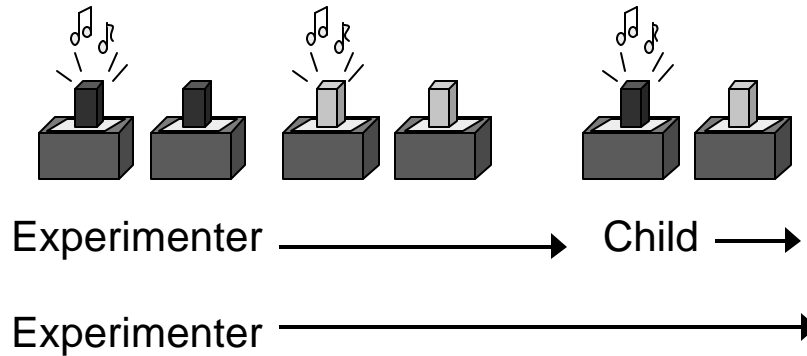

Conflicting
Intervention
Observation 2

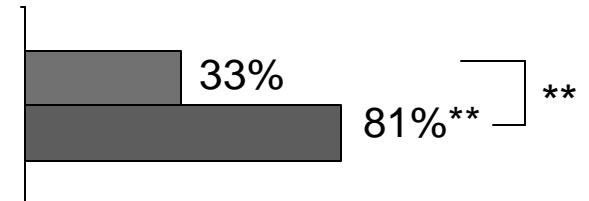
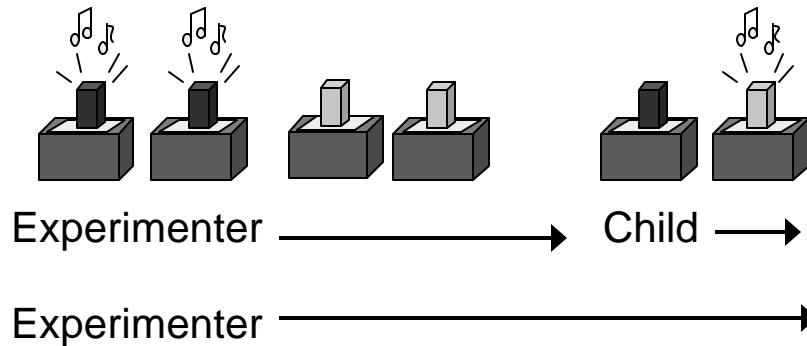

Hidden Cause Question: "Which one has more stuff inside?"

Accuracy on the Causal Structure Questions and Percentage of Learners who Responded Correctly on All Twelve questions in Experiment 1

	<u>Condition</u>			
	Self-Intervention		Obs. of Intervention	
	<u>Accuracy</u>	<u>Percentage</u>	<u>Accuracy</u>	<u>Percentage</u>
Chain Model	11.18	59	9.88	35
Diamond Model	11.06	24	9.47	24
Chain Model w/A→D	11.06	53	9.35	24
Common Effect & Chain	11.65	82	9.18	35

Accuracy on the Causal Structure Questions and Percentage of Learners who Responded Correctly on All Twelve questions in Experiment 2

	<u>Condition</u>			
	Self-Intervention		Forced Intervention	
	<u>Accuracy</u>	<u>Percentage</u>	<u>Accuracy</u>	<u>Percentage</u>
Chain Model	10.88	46	9.88	21
Diamond Model	10.96	25	9.88	17
Chain Model w/A→D	11.08	50	9.96	29
Common Effect & Chain	11.33	75	9.79	13

Mean Number of Interventions and Percentage of Critical Interventions Generated or Observed by Learners in Experiment 1

<u>Model</u>	<u>Mean Interventions</u>	<u>SD</u>	<u>Min</u>	<u>Max</u>	<u>%Critical</u>
Chain	44.29	16.33	25	79	15.38
Common Effect & Chain	40.53	18.09	25	72	21.27
Chain + AD	42.82	22.28	25	101	22.27
Diamond	45.53	18.68	25	96	25.39

Mean Number of Interventions and Percentage of Critical Interventions Generated or Observed by Learners in Experiment 2

<u>Model</u>	<u>Mean Interventions</u>	<u>SD</u>	<u>Min</u>	<u>Max</u>	<u>%Critical</u>
Chain	49.04	19.40	25	89	15.92
Common Effect & Chain	44.79	30.51	25	166	25.85
Chain + AD	48.71	25.96	25	120	23.94
Diamond	52.08	42.90	25	234	25.15